



YAMAHA

PARTS CATALOGUE

YZ465G (3R5)

103R5-300E1



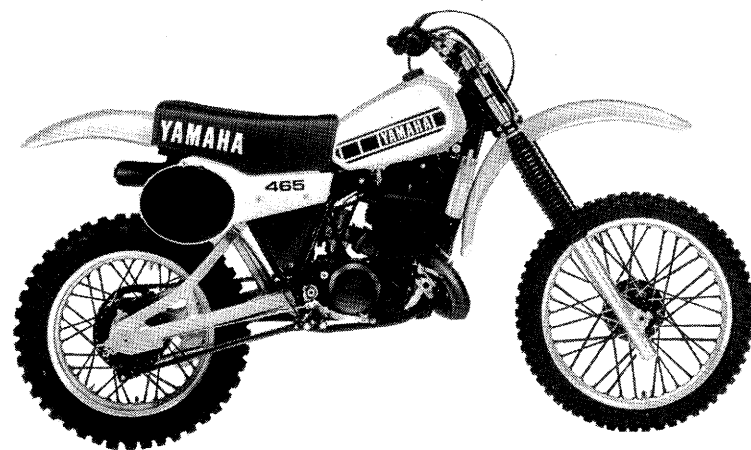
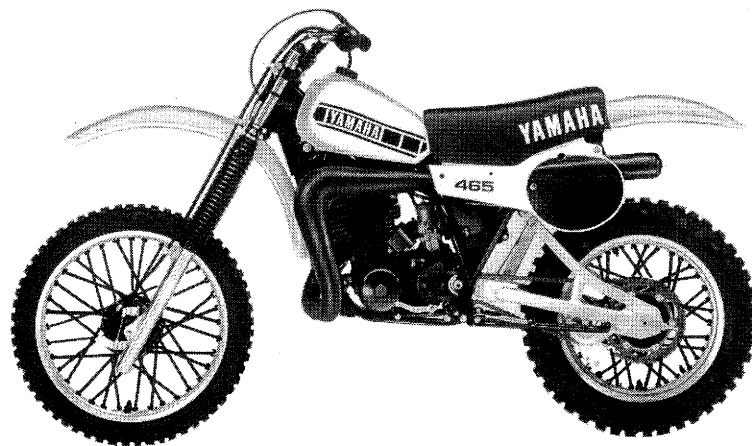

A3



FOREWORD

This Parts Catalogue is related to the parts in use for the Yamaha YZ 465G (3R5).
When you are ordering replacement parts for the YZ 465G (3R5), refer to this Parts Catalogue and quote both part numbers and part names correctly.

1. Modifications or additions which have been made after issue of the Parts Catalogue will be announced in the Yamaha Parts News.
It is advisable that according to the Yamaha Parts News you make necessary corrections to the Parts Catalogue on hand to keep it up-to-date.

2. Abbreviations

The following abbreviations are used in this Parts Catalogue.

- U.R. Use size (thickness) and/or number as required.
- U.N. Use as many as you need.
- A.P. Alternate Parts
- L.M. Local Made
- F# Frame No. (Applicable machine No.)

3. The parts marked with (*) in the parts number column of this Catalogue are not supplied with by Yamaha, those have to be found locally.
4. Parts, which are to be supplied in the form of assemblies, are listed with an indentation of one letter's space, and a dot (.) is put against the name of each part.

EXAMPLE CARBURETOR ASS'Y
 . JET, pilot
 . NOZZLE, main

5. Indication of No. of constituent parts for assembly

The numeral appearing to the right of each constituent part under the description indicates the quantity of such parts for each individual assembly unit.

EXAMPLE

Part No.	Description	Q'ty	Remarks
2F5-83310-60	FRONT FLASHER LIGHT ASS'Y	2	
115-83311-60	. BULB (6V-18W)	1	
1M1-83309-60	. REFLECTOR	1	

6. Initial Serial No. and Color Code

(A) Frame Serial No.	3R5-000101 and following
(B) Engine Serial No.	3R5-000101 and following

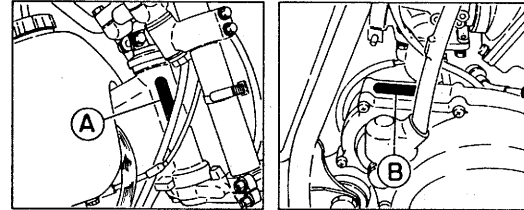

Color Code	Color Name	Abbreviate

7. Applicable colors of graphics are represented in the "Remarks" column by the letter(s) appropriately picked out of the full word(s) showing such colors.

EXAMPLE

Part No.	Description	Q'ty	Remarks
2N4-24110-00-X5	FUEL TANK COMP.	1	MAXIM RED
3J1-24240-10	. GRAPHIC, fuel tank set	1	for MXR

CONTENTS

ENGINE

Fig. 1	Cylinder	1
Fig. 2	Crankshaft - Piston	2
Fig. 3	C.D.I. Magneto	3
Fig. 4	Intake	4
Fig. 5	Carburetor	5
Fig. 6	Exhaust	7
Fig. 7	Crankcase	8
Fig. 8	Crankcase Cover	9
Fig. 9	Kick Starter	10
Fig. 10	Clutch	11
Fig. 11	Transmission	13
Fig. 12	Shift Cam - Fork	15
Fig. 13	Shift Shaft - Pedal	16

CHASSIS

Fig. 14	Frame - Tool	17
Fig. 15	Front Fender - Rear Fender	18
Fig. 16	Side Cover	19
Fig. 17	Rear Arm	20
Fig. 18	Rear Suspension	22
Fig. 19	Steering	24
Fig. 20	Front Fork	25
Fig. 21	Fuel Tank	27
Fig. 22	Seat	28
Fig. 23	Front Wheel	29
Fig. 24	Rear Wheel	31
Fig. 25	Handlebar - Cable	33
Fig. 26	Stand - Footrest	34
Fig. 27	Electrical 1	35
Fig. 28	Handle Switch - Lever	36

ALTERNATE PARTS

Fig. 29	Alternate (Chassis)	37
---------	---------------------	----

REPAIR KIT

Fig. 30	Repair Kit	38
---------	------------	----

INDEX

Numerical Index
Parts Name Index

FIG. 1 CYLINDER

REF. NO.	PART NO.	DESCRIPTION	Q'TY	REMARKS
1	3R5-11111-00	HEAD, cylinder 1	1	
2	3R5-11181-00	GASKET, cylinder head 1	1	
3	*	PLUG, sPark (CHAMPION N3)	1	LM
4	90116-08321	BOLT, stud	6	
5	90179-08299	NUT	6	
6	3R5-11311-00	CYLINDER 1	1	
7	3R5-11351-00	GASKET, cylinder	1	
8	90116-12315	BOLT, stud	2	
9	90116-12316	BOLT, stud	2	
10	95701-12100	NUT, flange	4	
11	91810-17016	PIN, dowel	2	

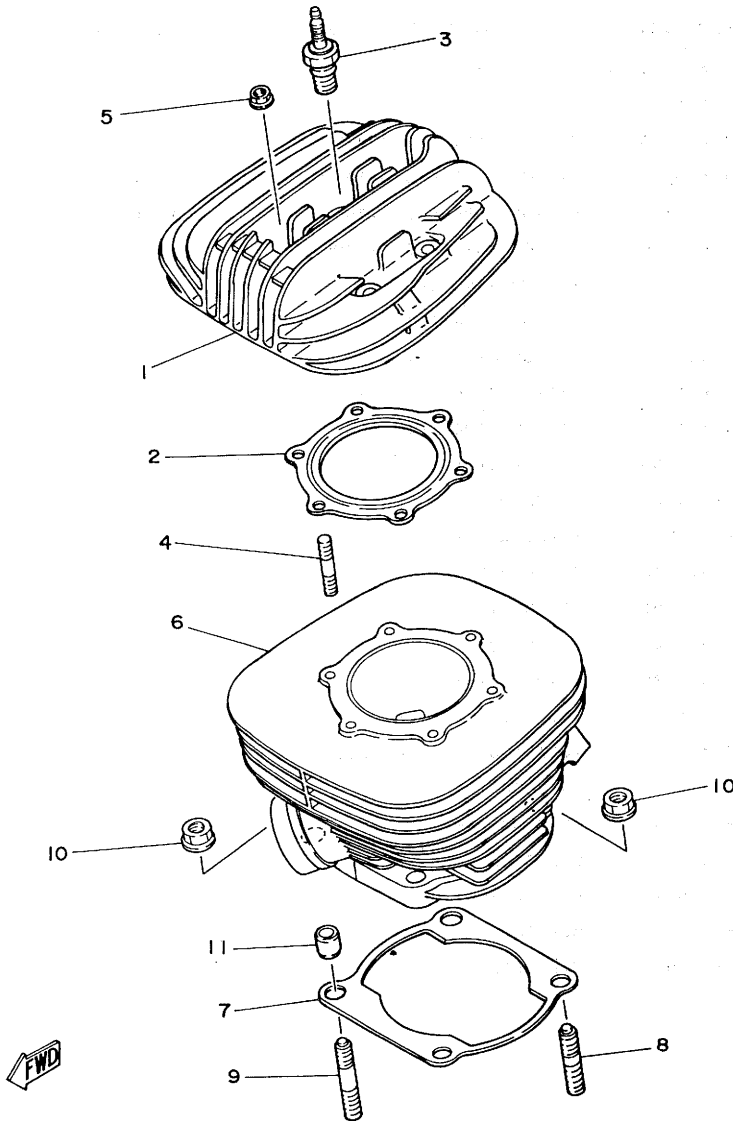

B2

FIG. 2 CRANKSHAFT•PISTON

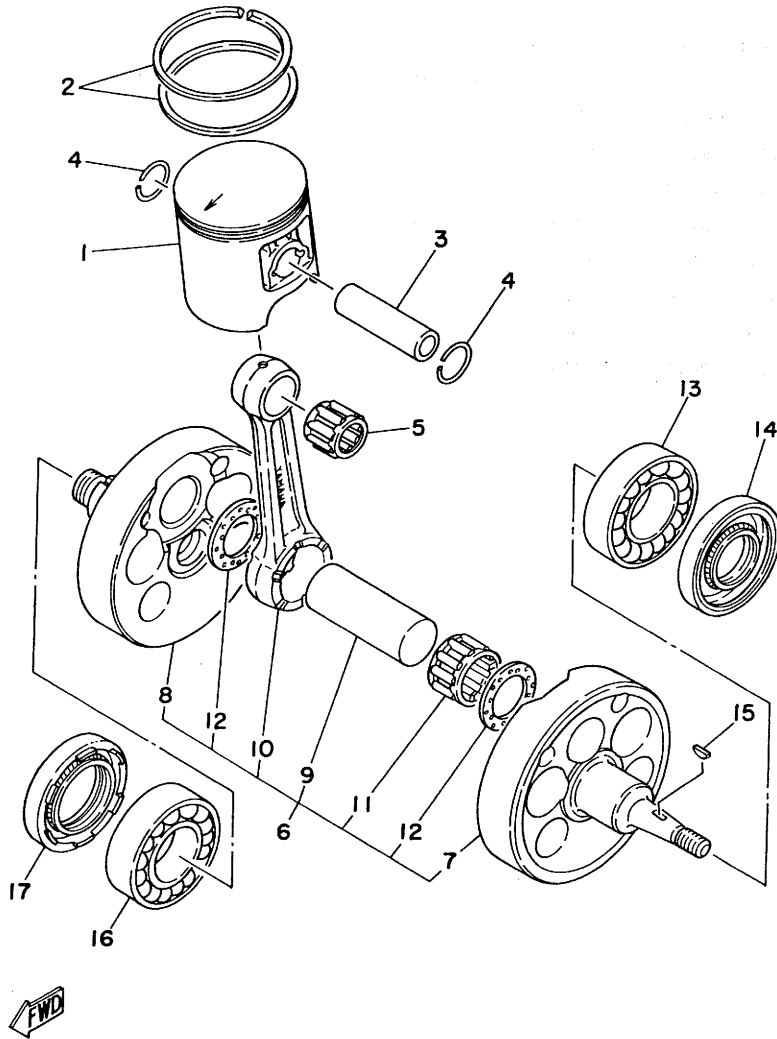

REF. NO.	PART NO.	DESCRIPTION	Q'TY	REMARKS
1	3R5-11631-00-94	PISTON (STD)	1	UR
	3R5-11631-00-96	PISTON (STD)	1	UR
	3R5-11635-00	PISTON (1ST O/S 0.25MM)	1	AP
	3R5-11636-00	PISTON (2ND O/S 0.50MM)	1	AP
	3R5-11637-00	PISTON (3RD O/S 0.75MM)	1	AP
	3R5-11638-00	PISTON (4TH O/S 1.00MM)	1	AP
2	3R5-11601-00	PISTON RING SET (STD)	1	
	3R5-11601-10	PISTON RING SET (1ST O/S)	1	AP
	3R5-11601-20	PISTON RING SET (2ND O/S)	1	AP
	3R5-11601-30	PISTON RING SET (3RD O/S)	1	AP
	3R5-11601-40	PISTON RING SET (4TH O/S)	1	AP
3	1W4-11633-00	PIN, Piston	1	
4	93450-19052	CIRCLIP	2	
5	93310-418E9	BEARING, cylindrical	1	
6	3R5-11400-00	CRANKSHAFT ASSY	1	
7	3R5-11412-00	•CRANK 1	1	
8	3R5-11422-00	•CRANK 2	1	
9	3R5-11681-00	•PIN, crank 1	1	
10	3R5-11651-00	•ROD, connecting	1	
11	93310-42541	•BEARING, cylindrical	1	
12	90209-25085	•WASHER	2	
13	93306-30615	BEARING (B6306)	1	
14	93103-30092	OIL SEAL	1	
15	90280-03017	KEY, woodruff	1	
16	93306-30615	BEARING (B6306)	1	
17	93103-40091	OIL SEAL	1	

FIG. 3 C.D.I. MAGNETO

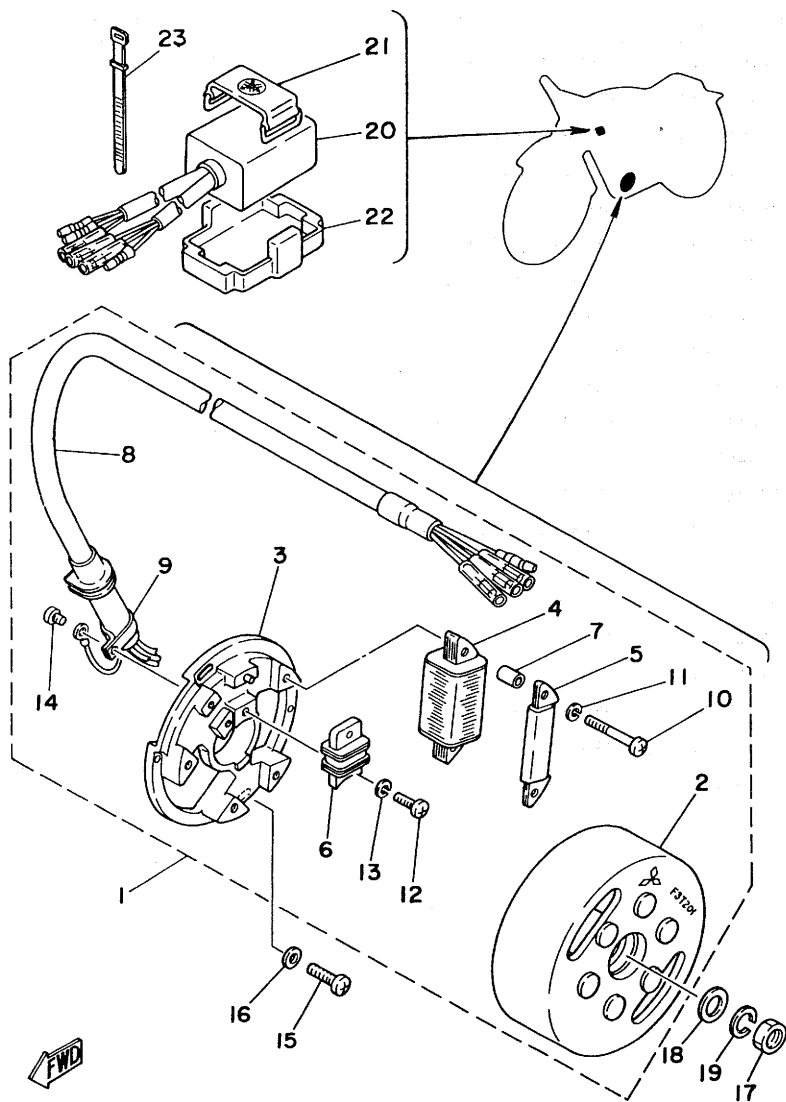

REF. NO.	PART NO.	DESCRIPTION	Q'TY	REMARKS
1	3R5-85500-20	C.D.I. MAGNETO ASSY	1	
2	3R5-85550-20	•ROTOR ASSY	1	
3	3R5-85509-20	•BASE, magneto	1	
4	3R5-85511-20	•COIL, source	1	
5	3R5-85512-20	•COIL, source	1	
6	2W6-85580-20	•COIL, Pulser	1	
7	1W2-85516-20	•SPACER	2	
8	3R5-85515-20	•LEAD WIRE ASSY	1	
9	104-81328-20	•CLAMP	1	
10	98501-04035	•SCREW, Pan head	2	
11	92901-04100	•WASHER, spring	2	
12	98501-04014	•SCREW, Pan head	1	
13	92901-04100	•WASHER, spring	1	
14	110-81345-21	•SCREW, Pan head	1	
15	92501-06020	SCREW, Pan head	3	
16	92901-06600	WASHER, Plate	3	
17	90170-12181	NUT	1	
18	90201-12593	WASHER, Plate	1	
19	92901-12100	WASHER, spring	1	
20	3R5-85540-20	C.D.I. UNIT ASSY	1	
21	116-82131-00	BAND, battery	1	
22	3R5-85547-00	DAMPER	1	
23	256-83936-00	BAND, switch cord	1	

B4

FIG. 4 INTAKE

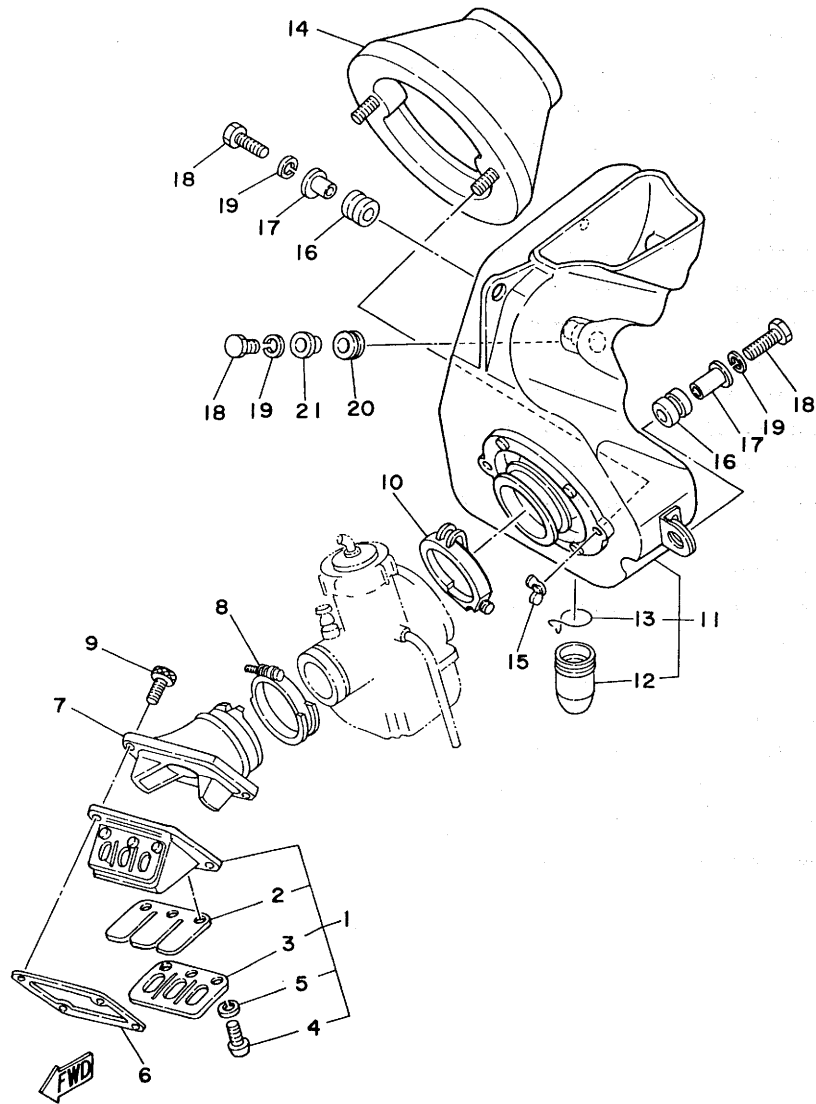

REF. NO.	PART NO.	DESCRIPTION	Q'TY	REMARKS
1	3R5-13610-00	REED VALVE ASSY	1	
2	3R5-13613-00	•REED, valve	2	
3	2X5-13616-00	•STOPPER, reed valve	2	
4	98501-03008	•SCREW, Pan head	6	
5	92901-03100	•WASHER, sPring	6	
6	2K7-13621-00	GASKET, valve seat	1	
7	3R4-13565-00	JOINT, carburetor	1	
8	90460-51109	CLAMP, hose	1	
9	91316-06020	BOLT	4	
10	90460-68120	CLAMP, hose	1	
11	3R4-14401-00	AIR CLEANER CASE ASSY	1	
12	1W4-14457-00	•SEAL	1	
13	90467-20030	•CLIP	1	
14	3R4-14450-00	ELEMENT ASSY, air cleaner	1	
15	90175-06012	NUT, wing	2	
16	90480-14102	GROMMET	2	
17	90387-07391	COLLAR	2	
18	97301-06025	BOLT	3	
19	92901-06100	WASHER, sPring	3	
20	90480-15058	GROMMET	1	
21	90387-07562	COLLAR	1	

FIG. 5 CARBURETOR

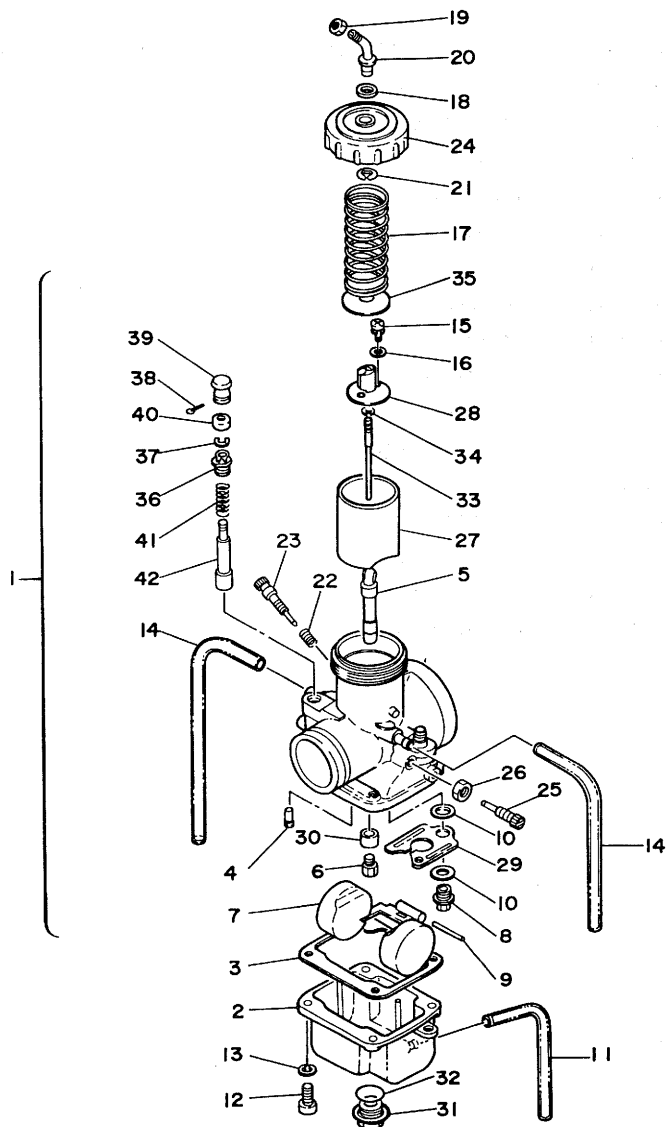

REF. NO.	PART NO.	DESCRIPTION	Q'TY	REMARKS
1	3R5-14101-00	CARBURETOR ASSY 1	1	
2	3R4-14181-16	•BODY, float chamber 1	1	
3	363-14184-00	•GASKET, float chamber	1	
4	193-14142-50	•JET, Pilot (#50.0)	1	
5	510-14141-48	•NOZZLE, main	1	
6	137-14143-78	•JET, main (#390)	1	UR STD
	137-14143-76	•JET, main (#380)	1	UR
	137-14143-80	•JET, main (#400)	1	UR
7	2N7-14185-00	•FLOAT	1	
8	363-14190-35	•NEEDLE VALVE ASSY	1	
9	537-14186-00	•PIN, float	1	
10	239-14195-00	•WASHER, needle valve	2	
11	2K7-14197-00	•PIPE	1	
12	98501-05015	•SCREW, Pan head	4	
13	92902-05100	•WASHER, sPrInG	4	
14	310-14197-00	•PIPE	2	
15	97602-03108	•SCREW, Pan head with washer	2	
16	92902-03600	•WASHER	2	
17	363-14131-00	•SPRING, throttle valve	1	
18	8F2-14147-00	•O-RING	1	
19	127-14161-00	•NUT, cable adjustInG	1	
20	3R4-14155-00	•GUIDE, cable	1	
21	363-14137-00	•CLIP	1	
22	127-14134-00	•SPRING, air adjustInG	1	
23	152-14123-00	•SCREW, air adjustInG	1	
24	3R4-14158-00	•TOP, mixInG chamber	1	
25	2A0-14122-00	•SCREW, throttle	1	
26	802-14161-00	•NUT, cable adjustInG	1	

FIG. 5 CARBURETOR

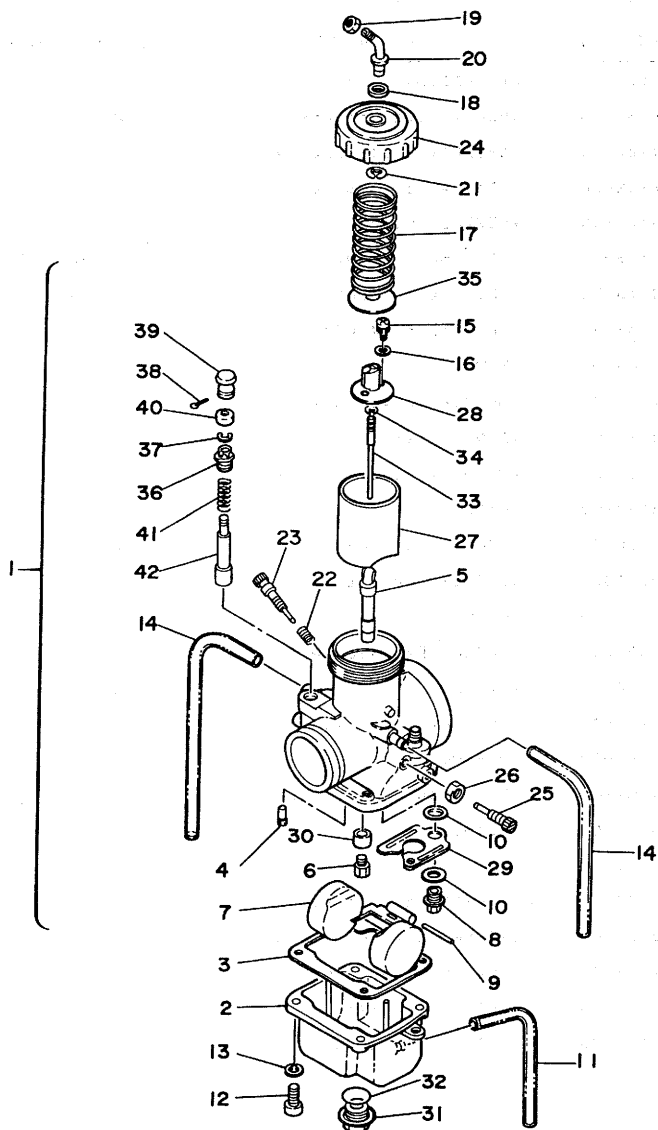

REF. NO.	PART NO.	DESCRIPTION	Q'TY	REMARKS
27	510-14112-30	•VALVE, throttle 1	1	
28	509-14274-00	•CONNECTOR	1	
29	3R4-14146-00	•PLATE	1	
30	2X8-14153-00	•WASHER, main Jet	1	
31	510-14115-00	•PLUG, screw	1	
32	558-14147-00	•O-RING	1	
33	239-14116-16	•NEEDLE	1	
34	164-14137-00	•CLIP	1	
35	509-14136-00	•SEAT, sPring	1	
36	152-14174-00	•CAP, PlunGer	1	
37	353-14138-00	•CLIP, PlunGer	1	
38	91402-16015	•PIN, cotter	1	
39	737-14261-00	•HOLDER	1	
40	637-14173-00	•COVER, PlunGer caP	1	
41	156-14135-00	•SPRING, PlunGer	1	
42	737-14171-00	•PLUNGER, starter	1	

FWD

B7

FIG. 6 EXHAUST

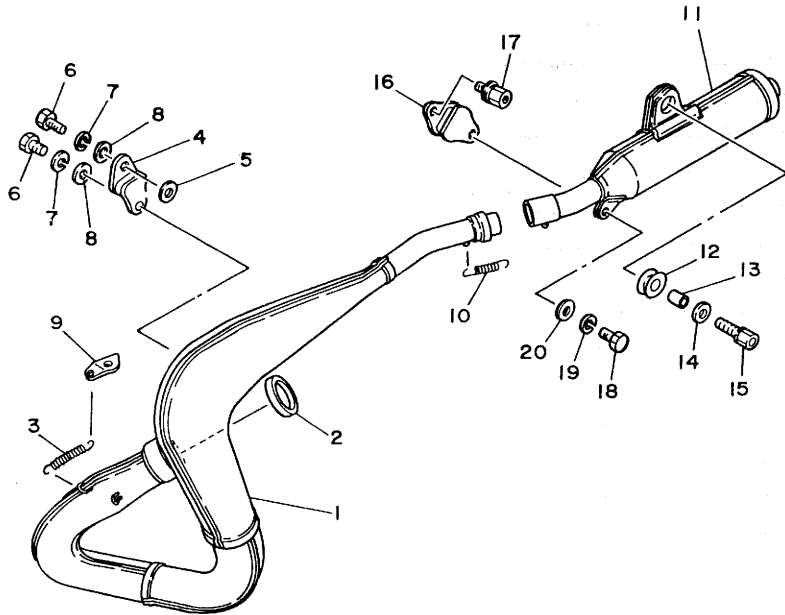

REF. NO.	PART NO.	DESCRIPTION	Q'TY	REMARKS
1	3R5-14610-00	EXHAUST PIPE ASSY 1	1	
2	3R4-14613-00	GASKET, exhaust Pipe	1	
3	90507-20030	SPRING, tension	3	
4	3R4-14781-02	STAY, muffler 2	1	
5	92901-08200	WASHER, Plain	1	
6	97301-08020	BOLT	2	
7	92901-08100	WASHER, sPring	2	
8	92901-08600	WASHER, Plate	2	
9	3R5-14619-00	HDOOK, sPring	1	
10	90506-20223	SPRING, tension	1	
11	3R5-14753-00	SILENCER, exhaust	1	
12	565-14747-00	DAMPER, muffler	1	
13	90387-08258	COLLAR	1	
14	156-24186-00	WASHER, sPecial	1	
15	90109-08512	BOLT	1	
16	565-14771-00	STAY, muffler 1	1	
17	90109-06551	BOLT	1	
18	97301-06016	BOLT	1	
19	92901-06100	WASHER, sPring	1	
20	92901-06600	WASHER, Plate	1	

FWD

B8

FIG. 7 CRANKCASE

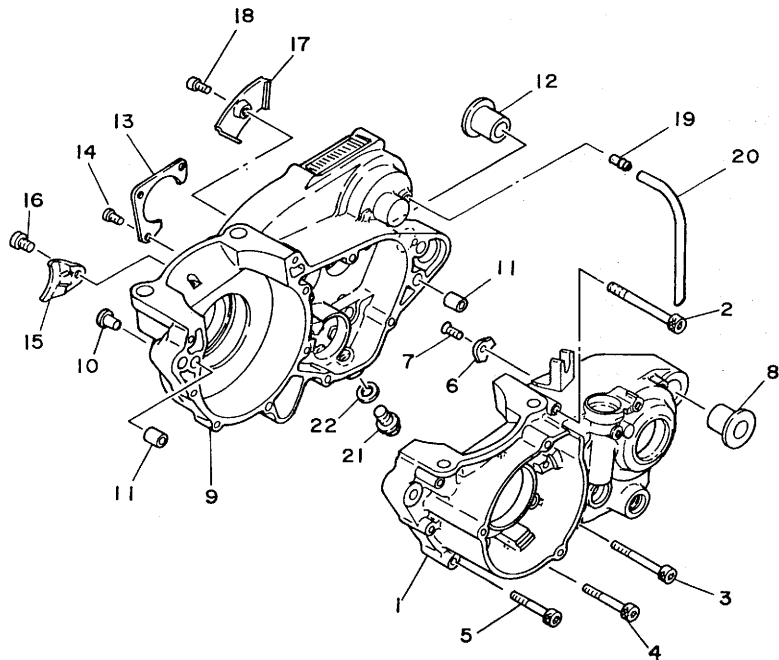
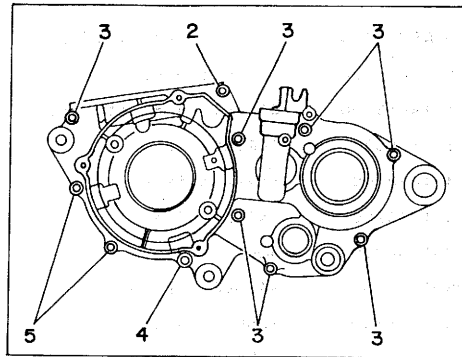

REF. NO.	PART NO.	DESCRIPTION	Q'TY	REMARKS
1	3R5-15111-00	CRANKCASE 1	1	
2	91316-06075	BOLT	1	
3	91316-06060	BOLT	7	
4	91316-06050	BOLT	1	
5	91316-06045	BOLT	2	
6	3R4-15383-00	PLATE, bearing cover	1	
7	92701-06012	SCREW, flat head	1	
8	90387-16776	COLLAR	1	
9	3R5-15121-00	CRANKCASE 2	1	
10	90338-07011	PLUG	1	
11	91810-05016	PIN, dowel	4	
12	90387-16776	COLLAR	1	
13	3R4-15381-00	PLATE, bearing cover	1	
14	92501-06012	SCREW, Pan head	3	
15	3R4-15118-00	HOLDER	1	
16	92501-08010	SCREW, Pan head	1	
17	3R4-15113-00	PLATE	1	
18	92501-06012	SCREW, Pan head	1	
19	137-13115-00	CONNECTOR, suction pipe	1	
20	90445-08376	HOSE	1	
21	90340-12059	PLUG, straight screw	1	
22	90430-12038	GASKET	1	

FIG. 8 CRANKCASE COVER

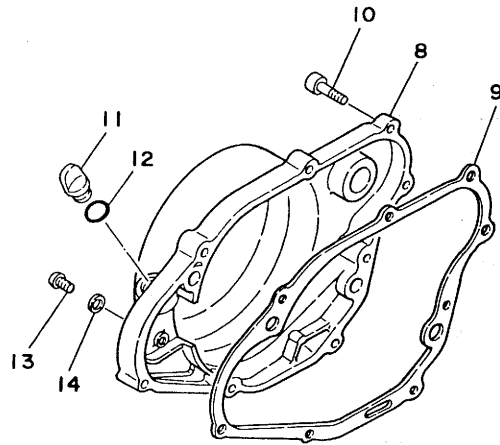

REF. NO.	PART NO.	DESCRIPTION	Q'TY	REMARKS
1	3R5-15411-00	COVER, crankcase 1	1	
2	3R5-15451-00	GASKET, crankcase cover	1	
3	92506-06035	SCREW, Pan head	3	
4	3R4-15421-00	COVER, crankcase 2	1	
5	92506-06025	SCREW, Pan head	1	
6	92906-06100	WASHER, sPring	1	
7	92906-06600	WASHER, Plate	1	
8	3R4-15431-00	COVER, crankcase 3	1	
9	3R4-15462-00	GASKET, crankcase cover 3	1	
10	91316-06025	BOLT	8	
11	1G8-15362-00	PLUG, oil level	1	
12	93210-14104	O-RING	1	
13	92506-06008	SCREW, Pan head	1	
14	90430-06016	GASKET	1	

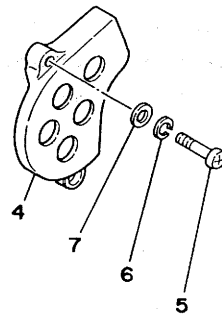
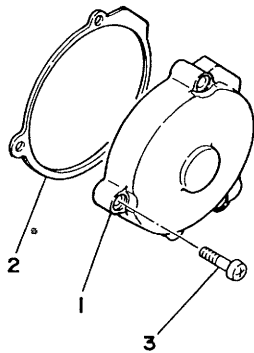
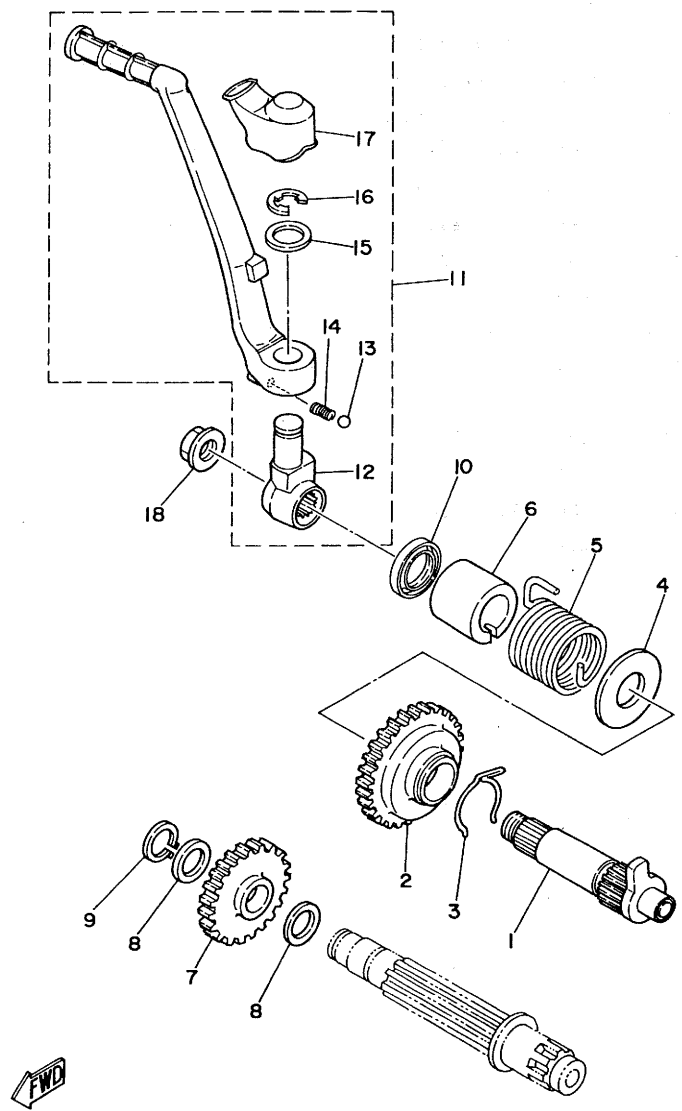

FIG. 9 KICK STARTER



REF. NO.	PART NO.	DESCRIPTION	Q'TY	REMARKS
1	3R4-15660-00	KICK AXLE ASSY	1	
2	3R4-15641-00	GEAR, kick (26T)	1	
3	90468-26048	CLIP	1	
4	90201-20358	WASHER, Plate	1	
5	90508-30422	SPRING, torsion	1	
6	3R4-15664-00	GUIDE, sPring	1	
7	3R4-15651-00	GEAR, sProcket idle (21T)	1	
8	90201-17545	WASHER, Plate	2	
9	93410-17008	CIRCLIP	1	
10	93109-20014	DIL SEAL	1	
11	3R4-15620-00	KICK CRANK ASSY	1	
12	3R4-15621-01	•BOSS, kick crank	1	
13	93507-32009	•BALL	1	
14	90501-12081	•SPRING, comPression	1	
15	90201-15234	•WASHER, Plate	1	
16	93430-10016	•CIRCLIP	1	
17	2K7-15618-00	•COVER, kick lever	1	
18	90179-12244	NUT	1	

B11

FIG. 10 CLUTCH

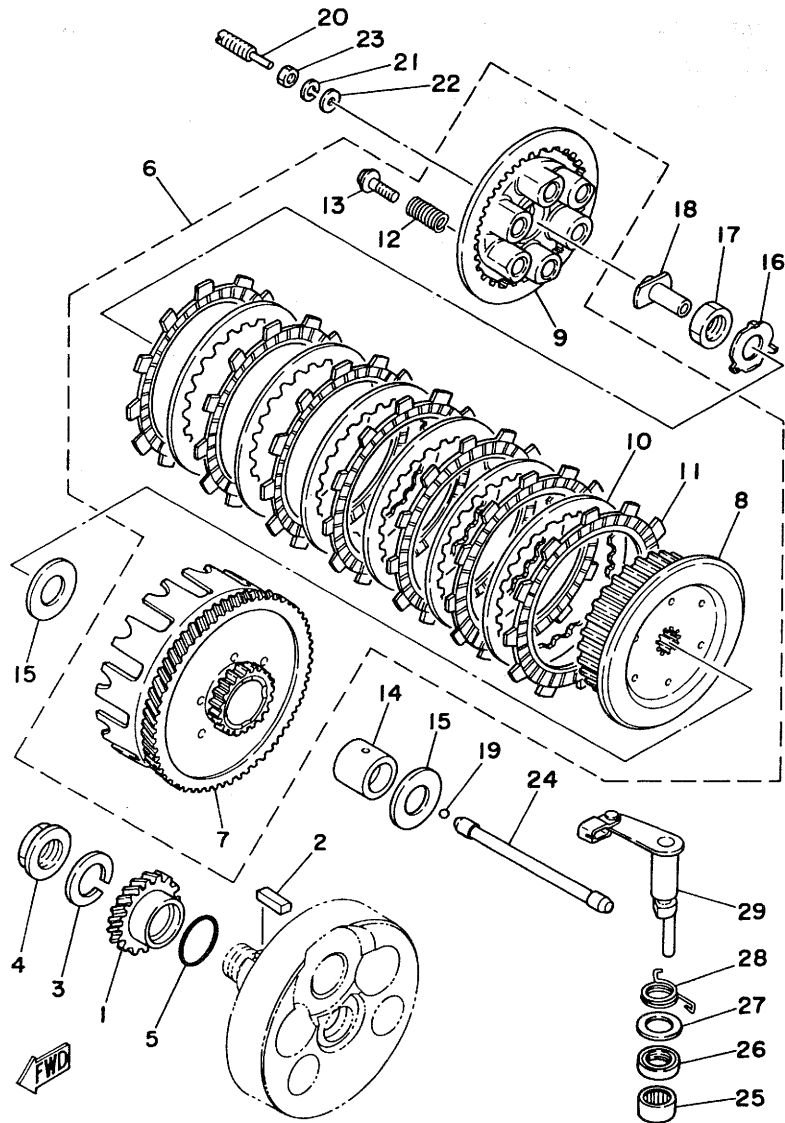

REF. NO.	PART NO.	DESCRIPTION	Q'TY	REMARKS
1	3R5-16111-00	GEAR, Primary drive (24T)	1	
2	90282-07019	KEY, straight	1	
3	92901-18100	WASHER, sPring	1	
4	90170-18089	NUT	1	
5	93210-29282	O-RING	1	
6	3R5-16300-00	CLUTCH ASSY	1	
7	3R4-16150-00	•PRIMARY DRIVEN GEAR COMP.(63T)	1	
8	3R4-16371-00	•BOSS, clutch	1	
9	1M1-16351-00	•PLATE, Pressure 1	1	
10	168-16325-00	•PLATE, clutch 2	6	
11	383-16321-00	•PLATE, friction	7	
12	90501-24408	•SPRING, compression	6	
13	90159-06016	•SCREW, with washer	6	
14	2K7-16181-00	SPACER 1	1	
15	2K7-16154-00	PLATE, thrust 1	2	
16	90215-20125	WASHER, lock	1	
17	90170-20255	NUT	1	
18	3R4-16356-00	RDD, Push 1	1	
19	93515-32029	BALL	1	
20	90149-08143	SCREW	1	
21	92901-08100	WASHER, sPring	1	
22	90201-08092	WASHER, Plate	1	
23	95311-08700	NUT	1	
24	3R5-16357-00	RDD, Push 2	1	
25	93315-21721	BEARING, cylindrical	1	
26	93102-17004	OIL SEAL	1	
27	90201-17327	WASHER, Plate	1	

B12

FIG. 10 CLUTCH

REF. NO.	PART NO.	DESCRIPTION	Q'TY	REMARKS
28	90508-14423	SPRING, torsion	1	
29	3R4-16380-01	PUSH LEVER ASSY	1	

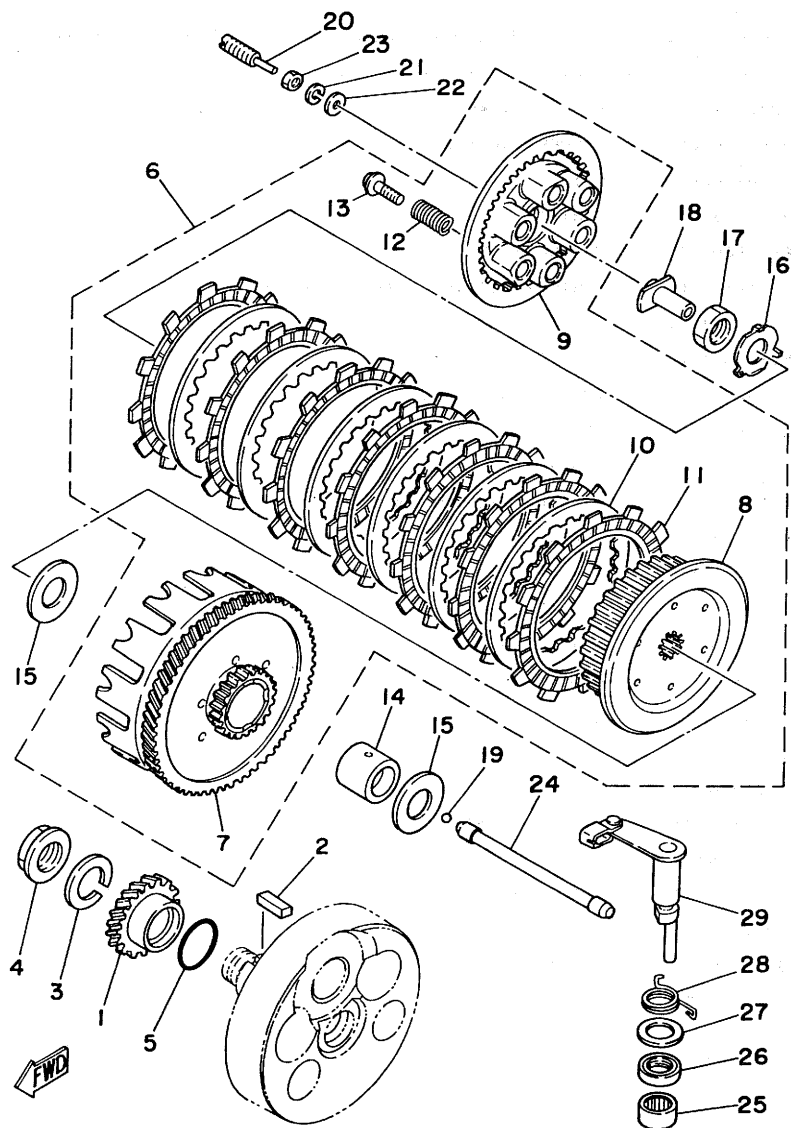

B13

FIG. 11 TRANSMISSION

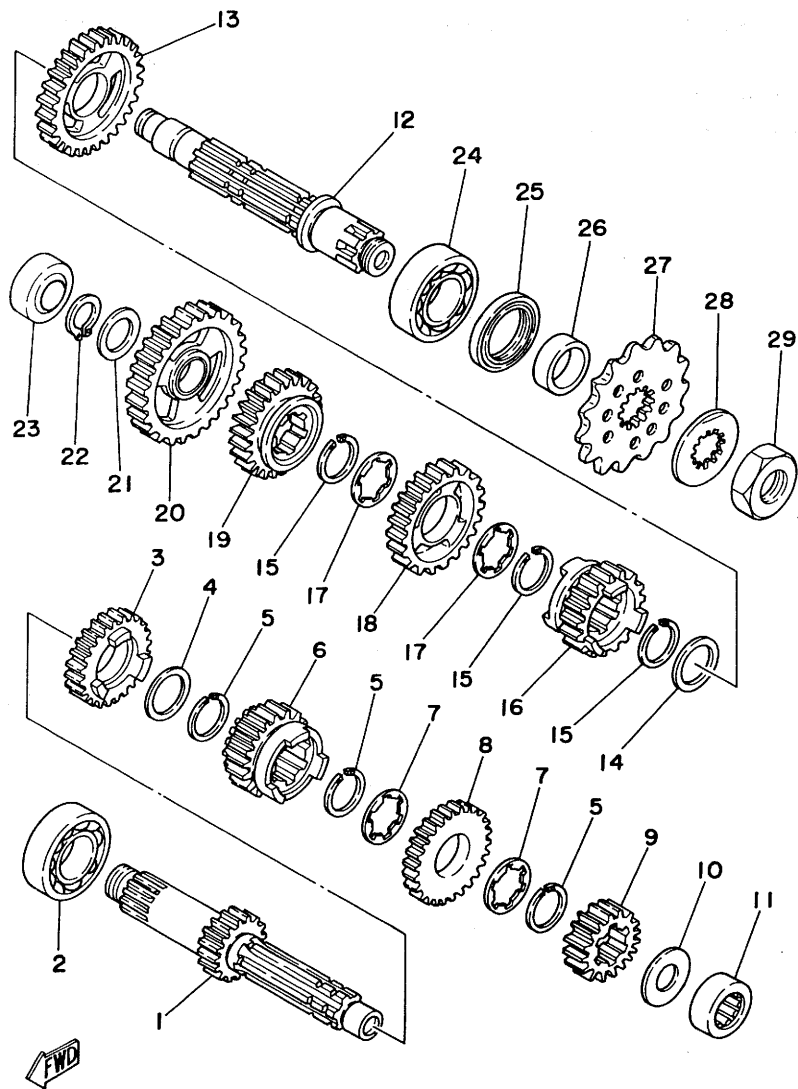

REF. NO.	PART NO.	DESCRIPTION	Q*TY	REMARKS
1	3R5-17411-00	AXLE, main (14T)	1	
2	93306-20540	BEARING	1	
3	3R5-17141-00	GEAR, 4th Pinion (22T)	1	
4	90201-25287	WASHER, Plate	1	
5	93440-25019	CIRCLIP	3	
6	3R5-17131-00	GEAR, 3rd Pinion (19T)	1	
7	90209-22082	WASHER	2	
8	3R5-17151-00	GEAR, 5th Pinion (24T)	1	
9	3R5-17121-00	GEAR, 2nd Pinion (16T)	1	
10	90201-20278	WASHER, Plate	1	
11	93311-62035	BEARING, cylindrical	1	
12	3R5-17421-00	AXLE, drive	1	
13	3R5-17221-00	GEAR, 2nd wheel (28T)	1	
14	90201-25287	WASHER, Plate	1	
15	93440-25019	CIRCLIP	3	
16	3R5-17251-00	GEAR, 5th wheel (20T)	1	
17	90209-22082	WASHER	2	
18	3R5-17231-00	GEAR, 3rd wheel (25T)	1	
19	2X5-17241-00	GEAR, 4th wheel (23T)	1	
20	3R5-17211-00	GEAR, 1st wheel (30T)	1	
21	90201-20278	WASHER, Plate	1	
22	93410-20038	CIRCLIP	1	
23	93311-62035	BEARING, cylindrical	1	
24	93306-20544	BEARING	1	
25	93102-32136	OIL SEAL	1	
26	90387-25663	COLLAR	1	
27	1W4-17461-40	SPROCKET, drive (14T)	1	UR STD
	1W4-17461-30	SPROCKET, drive (13T)	1	UR

FIG. 11 TRANSMISSION

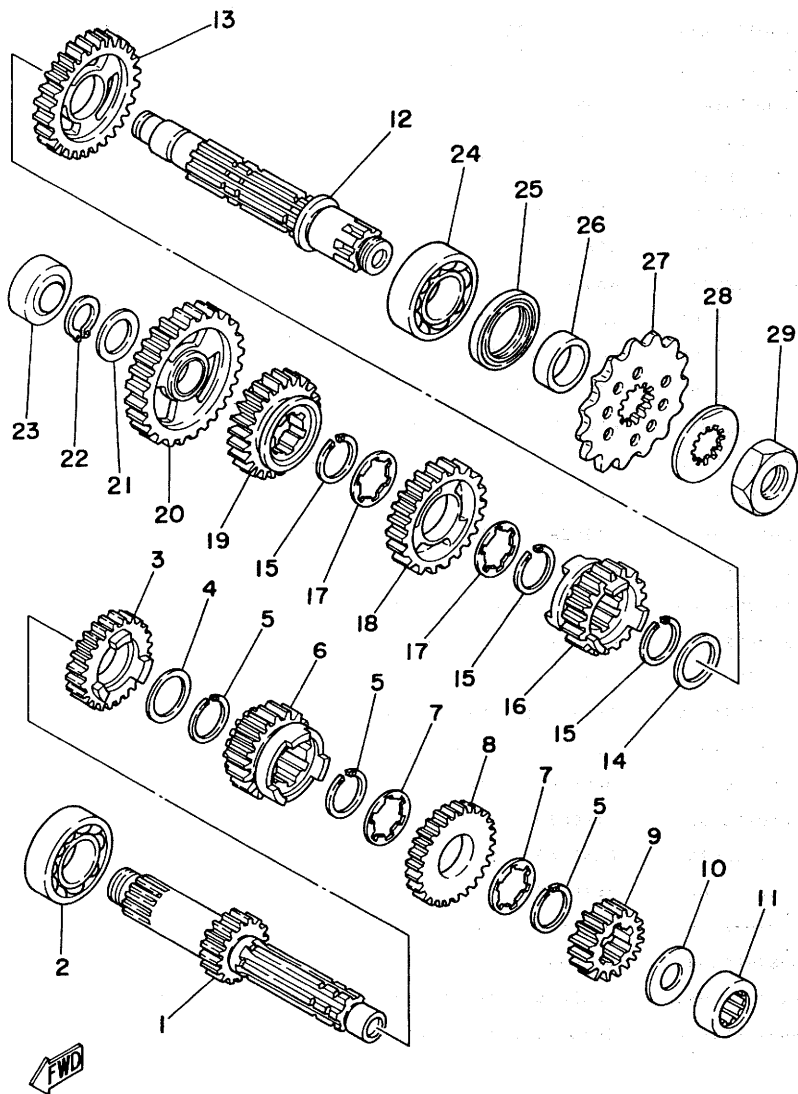

REF. NO.	PART NO.	DESCRIPTION	Q'TY	REMARKS
27	1W4-17461-50	SPROCKET, drive (15T)	1	UR
28	90215-21121	WASHER, lock	1	
29	90179-20255	NUT	1	

B15

FIG. 12 SHIFT CAM.FORK

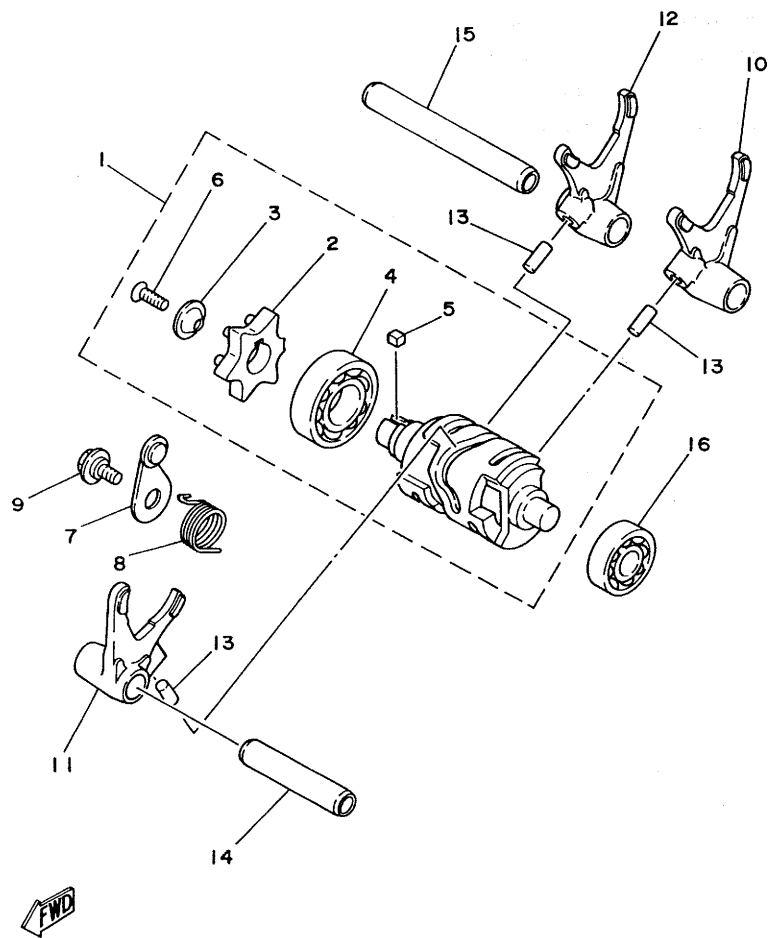

REF. NO.	PART NO.	DESCRIPTION	Q'TY	REMARKS
1	3R5-18540-00	SHIFT CAM ASSY	1	
2	3R4-18185-00	•SEGMENT	1	
3	3R4-18561-00	•PLATE, side 1	1	
4	93306-00421	•BEARING	1	
5	90282-04036	•KEY, straight	1	
6	98701-05016	•SCREW, flat head	1	
7	3R4-18140-00	STOPPER LEVER ASSY	1	
8	90508-26421	SPRING, torsion	1	
9	1W1-18177-00	BOLT, stopPer	1	
10	3R5-18511-00	FORK, shift 1	1	
11	3R5-18512-00	FORK, shift 2	1	
12	3R5-18513-00	FORK, shift 3	1	
13	93606-14154	PIN, dowel	3	
14	3R4-18531-00	BAR, shift fork Guide 1	1	
15	3R4-18535-00	BAR, shift fork Guide 2	1	
16	93306-20107	BEARING (B6201)	1	

FIG. 13 SHIFT SHAFT•PEDAL

REF. NO.	PART NO.	DESCRIPTION	Q'TY	REMARKS
1	3R4-18101-01	SHIFT SHAFT ASSY	1	
2	3R5-18111-00	PEDAL, shift	1	
3	97321-06025	BOLT	1	
4	93101-12004	OIL SEAL	1	
5	93608-25150	PIN, dowel	1	
6	90560-12171	SPACER	1	
7	90508-32374	SPRING, torsion	1	

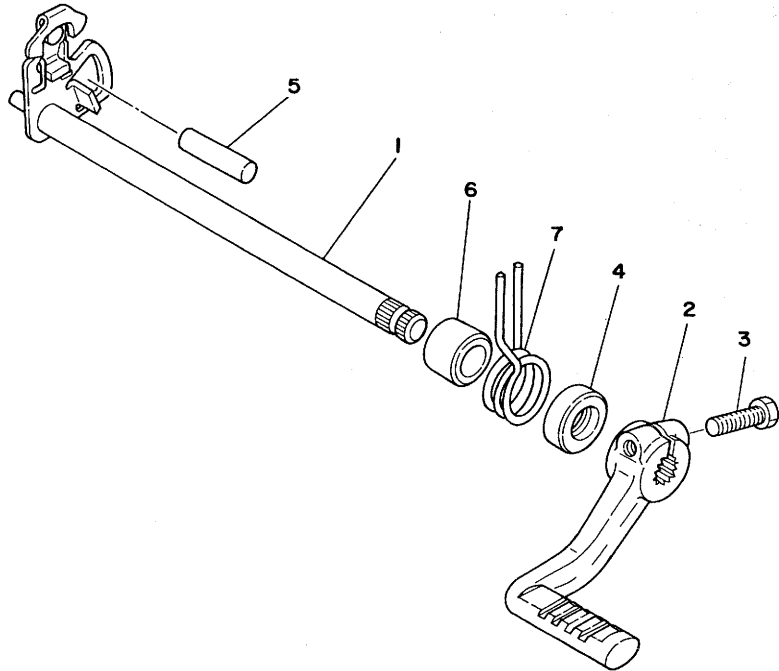

C3

FIG. 14 FRAME. TOOL

REF. NO.	PART NO.	DESCRIPTION	Q'TY	REMARKS
1	3R4-21110-00-33	FRAME COMP	1	yamaha black
2	3R4-21415-00	BRACKET, front upper 1	2	
3	95801-08075	BOLT, flange	2	
4	3R5-21425-00	BRACKET, rear upper 1	1	
5	97301-08025	BOLT	2	
6	92901-08100	WASHER, sPring	2	
7	92901-08600	WASHER, Plate	2	
8	95811-08075	BOLT, flange	1	
9	95811-10055	BOLT, flange	1	
10	92901-10200	WASHER, Plain	2	
11	95601-10100	NUT, u	1	
12	95811-08165	BOLT, flange	1	
13	92901-08200	WASHER, Plain	4	
14	90185-08054	NUT, self-locking	4	
15	90339-13005	PLUG	2	
16	2K7-2148A-00	SHAFT	2	
17	2K6-22178-00	TENSIONER	2	
18	90201-13202	WASHER, Plate	4	
19	92901-08200	WASHER, Plain	2	
20	97301-08055	BOLT	2	
21	95702-08300	NUT, flange	2	
22	92901-08600	WASHER, Plate	2	
23	3R4-2139W-00	COVER	1	
24	2K7-28100-10	TOOL KIT	1	
25	2K7-85555-00	•PULLER, rotor	1	
26	1W1-28135-10	•SPANNER, sPecial	1	
27	2X4-2811A-00	GAUGE, air	1	

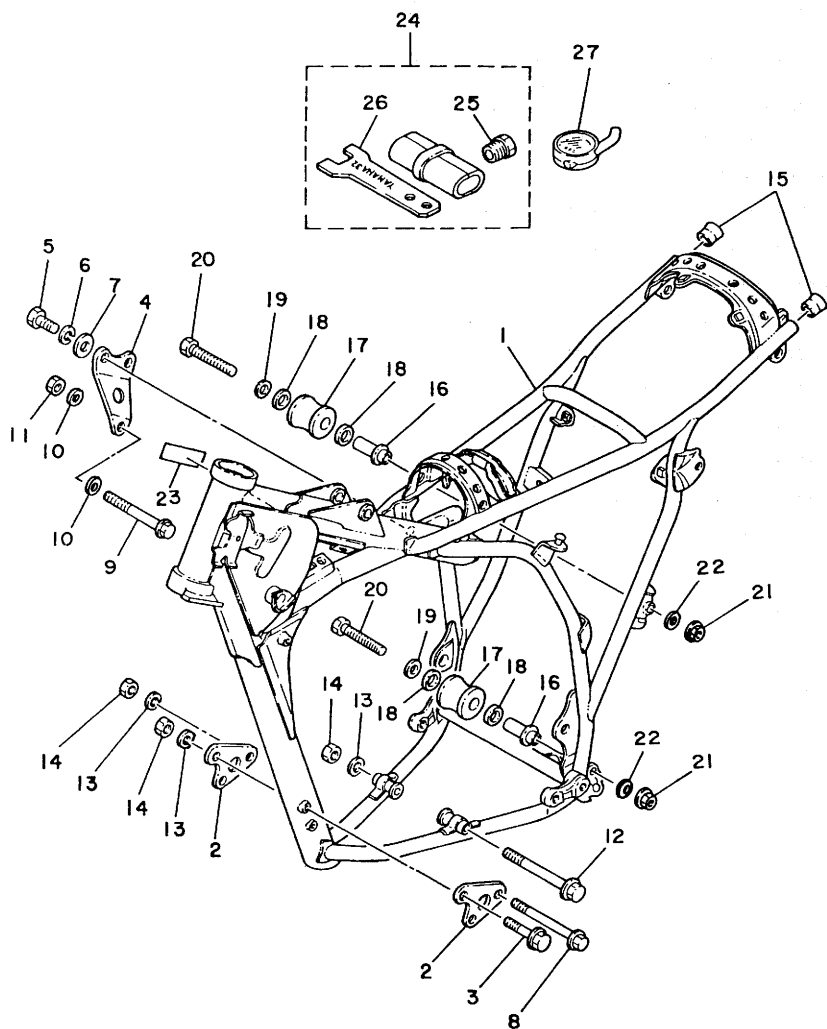
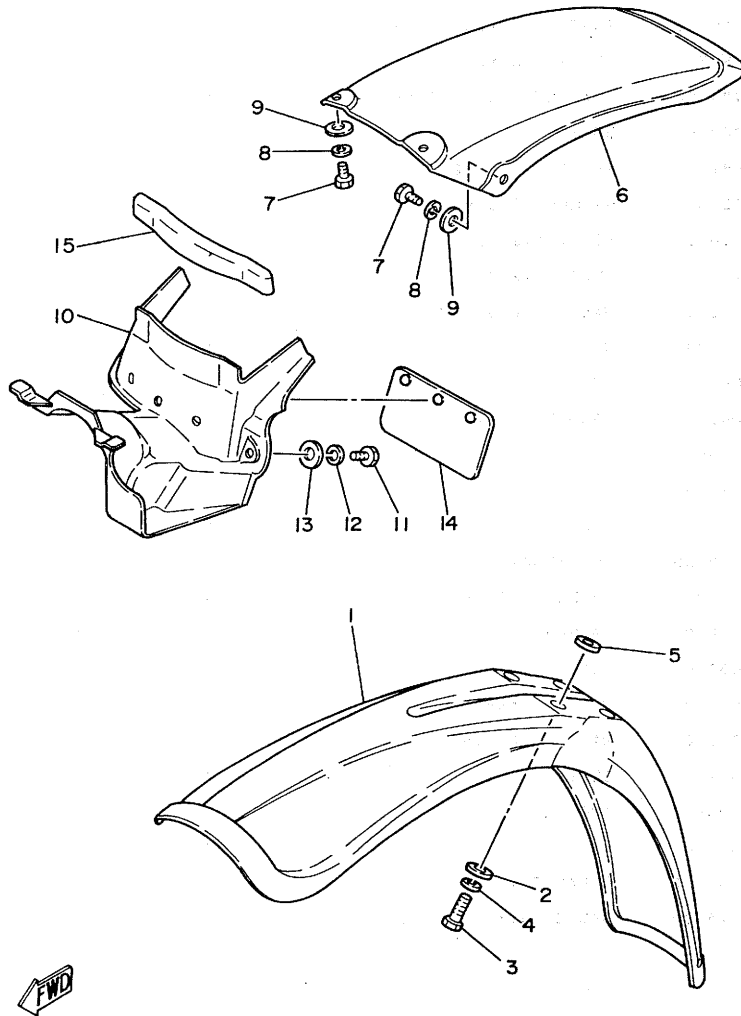

FIG. 15 FRONT FENDER•REAR FENDER



REF. NO.	PART NO.	DESCRIPTION	Q'TY	REMARKS
1	3R8-21511-00	FENDER, front	1	clean white
2	90201-06067	WASHER, Plate	4	
3	97302-06020	BOLT	4	
4	92902-06100	WASHER, sPring	4	
5	90209-06187	WASHER	4	
6	3R4-21611-10	FENDER, rear	1	clean white
7	97301-06015	BOLT	4	
8	92902-06100	WASHER, sPring	4	
9	90201-06067	WASHER, Plate	4	
10	3R4-21629-00	GUARD, mud	1	
11	97301-06015	BOLT	2	
12	92902-06100	WASHER, sPring	2	
13	90201-06067	WASHER, Plate	2	
14	1M1-21621-00	FLAP	1	
15	565-21746-00	SEAL, mud Guard	1	



C5

FIG. 16 SIDE COVER

REF. NO.	PART NO.	DESCRIPTION	Q'TY	REMARKS
1	3R4-21711-10-98	COVER, side (L.H)	1	low gloss black /clean white
2	92902-08200	WASHER	2	
3	92501-06015	SCREW, Pan head	2	
4	92901-06100	WASHER, sPring	2	
5	90201-06571	WASHER, Plate	2	
6	90480-12053	GROMMET	1	
7	431-24181-00	DAMPER, locating 1	4	
8	3R4-21721-10-98	COVER, side (R.H)	1	low gloss black /clean white
9	3R4-21746-00	DAMPER	1	
10	3R8-21746-00	DAMPER	1	
11	3R4-21732-00	SEAL 1	1	
12	3R4-2172A-00	PANEL 1	1	
13	97702-40512	SCREW, tapping	2	
14	92902-04200	WASHER, Plain	2	
15	92501-06012	SCREW, Pan head	3	
16	92901-06100	WASHER, sPring	3	
17	92901-06200	WASHER, Plain	3	
18	92501-06015	SCREW, Pan head	1	
19	92901-06100	WASHER, sPring	1	
20	90201-06571	WASHER, Plate	1	
21	3R5-21737-00	EMBLEM	2	

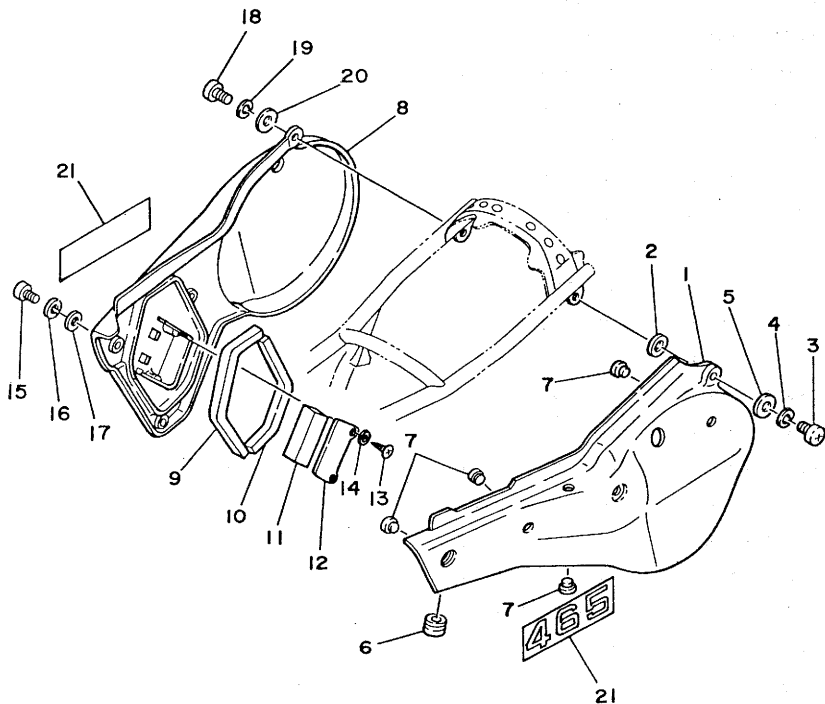

FWD

C6

FIG. 17 REAR ARM

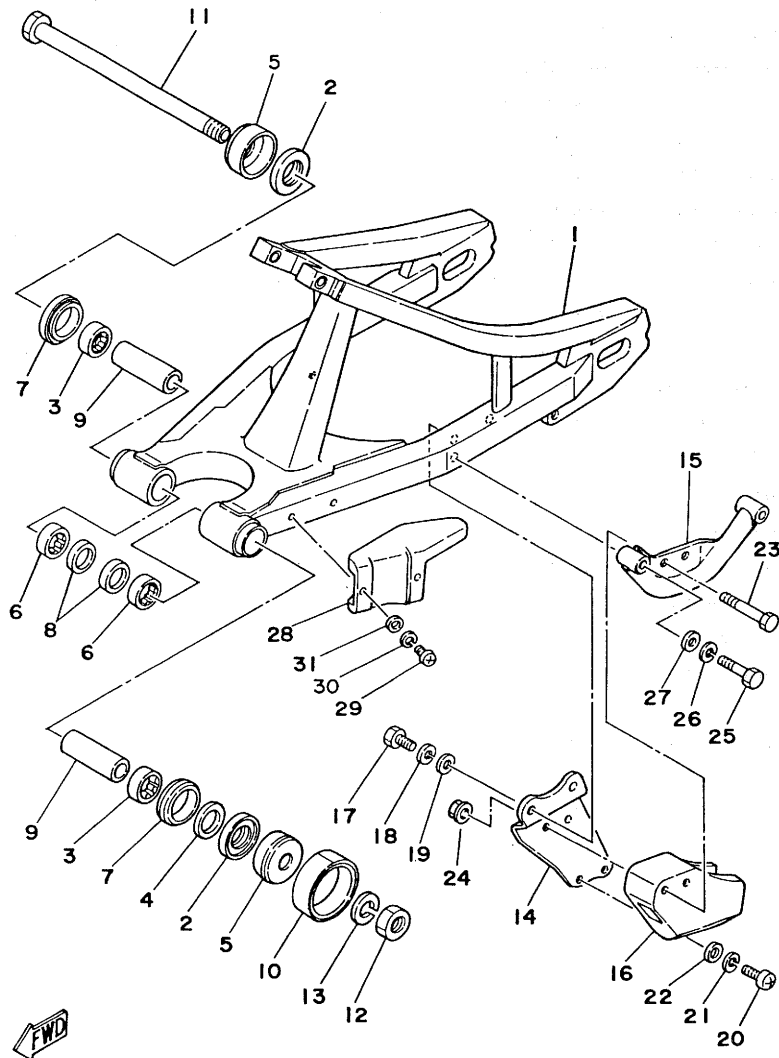

REF. NO.	PART NO.	DESCRIPTION	Q'TY	REMARKS
1	3R5-22110-00-35	REAR ARM COMP.	1	silver
2	93342-22208	BEARING	2	
3	93317-22214	BEARING, cylindrical	2	
4	648-45533-00-03	SHIM (0.3T)	1	UN
5	3R4-22129-00	COVER, thrust 2	2	
6	90386-22097	BUSH	2	
7	93108-35004	OIL SEAL	2	
8	93109-22018	OIL SEAL	2	
9	90380-16077	BUSH, solid	2	
10	2W6-22151-00	SEAL, Guard	1	
11	3R4-22141-00	SHAFT, Pivot	1	
12	90170-16111	NUT	1	
13	92901-16100	WASHER, sPring	1	
14	2X4-22179-00	ARM, tensioner	1	
15	3R5-22153-00	GUARD, chain	1	
16	2X4-22199-00	SUPPORT, chain	1	
17	97301-08016	BOLT	2	
18	92901-08100	WASHER, sPring	2	
19	92901-08600	WASHER, Plate	2	
20	92501-06020	SCREW, Pan head	2	
21	92901-06100	WASHER, sPring	2	
22	92901-06600	WASHER, Plate	2	
23	97301-06050	BOLT	2	
24	95702-06300	NUT, flange	2	
25	97301-08035	BOLT	2	
26	92901-08100	WASHER, sPring	2	
27	92901-08600	WASHER, Plate	2	
28	3R4-22147-00	PROTECTOR, chain	1	

C7

FIG. 17 REAR ARM

REF. NO.	PART NO.	DESCRIPTION	Q'TY	REMARKS
29	98501-05010	SCREW, Pan head	2	
30	92901-05100	WASHER, sPring	2	
31	92901-05200	WASHER, Plain	2	

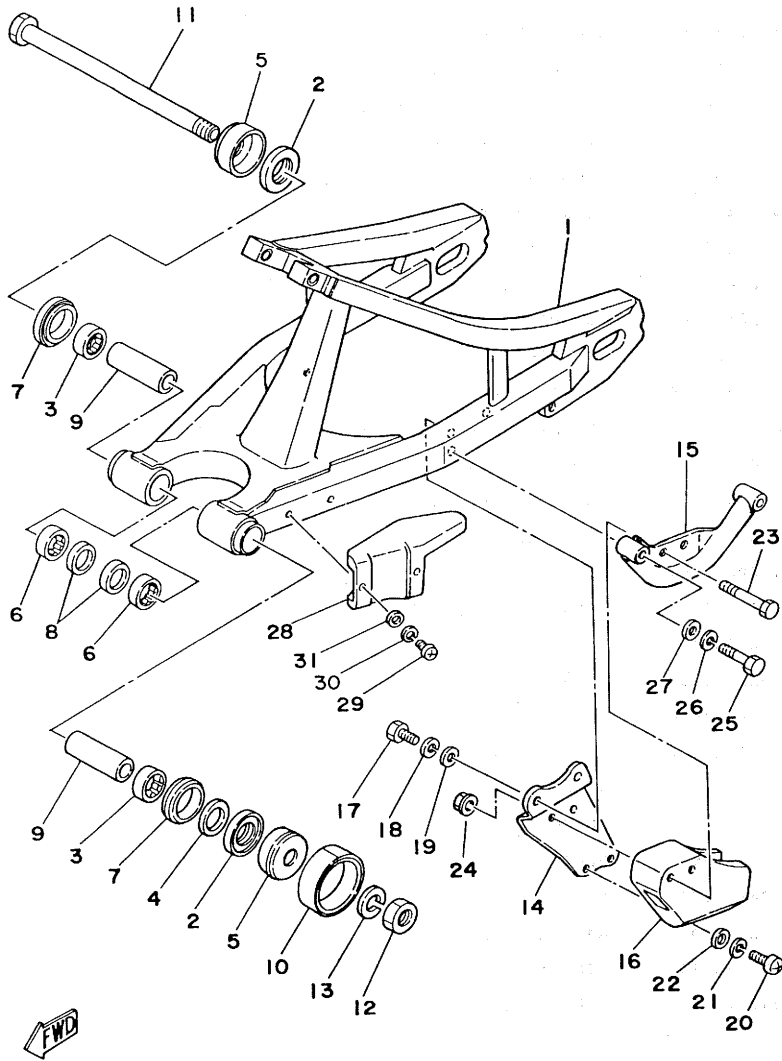

C8

FIG. 18 REAR SUSPENSION

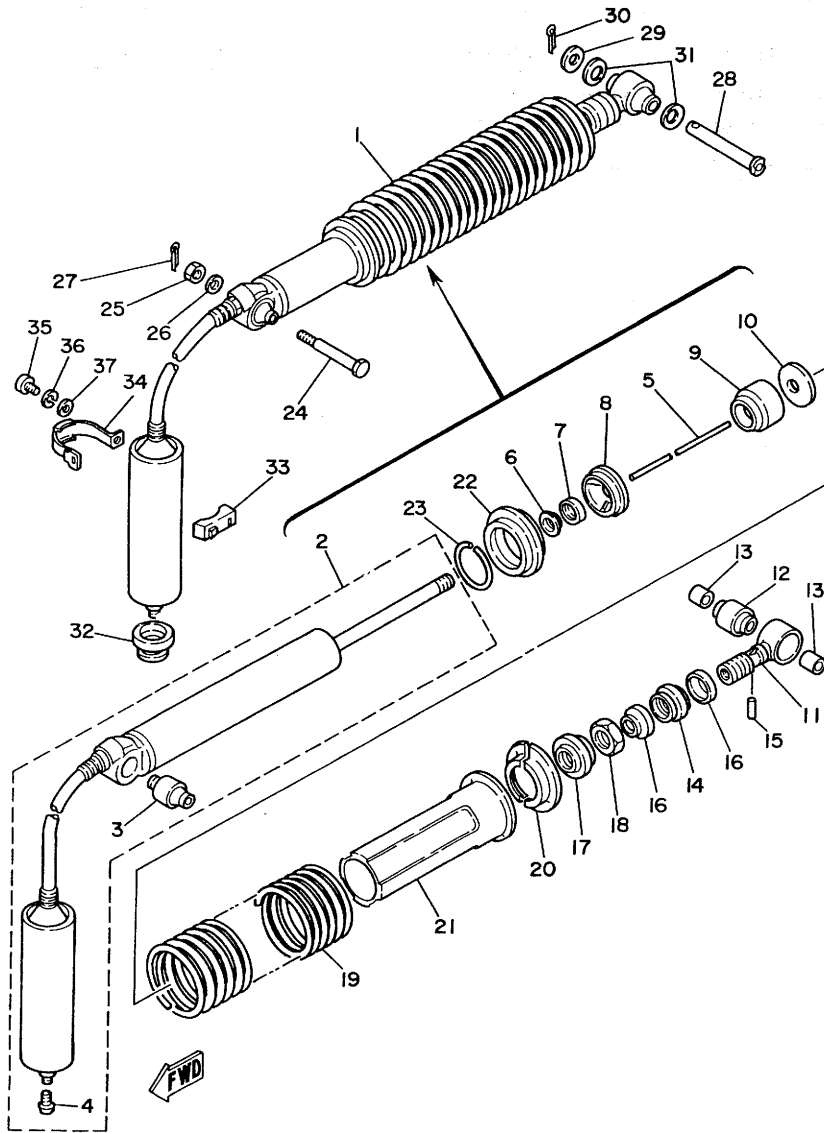

REF. NO.	PART NO.	DESCRIPTION	Q'TY	REMARKS
1	3R4-22210-00	SHOCK ABSORBER ASSY, rear	1	
2	3R4-22401-00	•DUMPER SUB ASSY	1	
3	1W1-22216-00	••BUSH, rear shock absorber	1	
4	98501-04005	••SCREW, Pan head	1	
5	3R4-22489-00	•ROD, Push	1	
6	3R4-22475-00	•SEAL, dust	1	
7	3R4-22473-00	•HOUSING, seal ring	1	
8	3R4-22472-00	•CAP, case	1	
9	1W1-22493-00	•STOPPER, bump	1	
10	3R4-22228-00	•SUPPORT, bump stop	1	
11	3R4-22409-00	•UPPER BRACKET SUB ASSY	1	
12	3R4-22226-00	•BUSH, shock absorber lower	1	
13	90380-12051	•BUSH, solid	2	
14	3R4-22497-00	•NUT, adjusting	1	
15	93604-26132	•PIN, dowel	1	
16	3R4-22221-01	•COVER	2	
17	3R4-22213-00	•SEAT, spring upper	1	
18	90170-20213	•NUT	1	
19	3R4-22212-00	•SPRING	1	
20	3R4-22214-00	•GUIDE, spring 1	2	
21	3R4-22224-00	•GUIDE, spring 2	1	
22	3R4-22223-00	•SEAT, spring lower	1	
23	93440-50078	•CIRCLIP	1	
24	90109-10550	BOLT	1	
25	95302-10700	NUT	1	
26	92902-10600	WASHER, Plate	1	
27	91401-20025	PIN, cotter	1	
28	90240-12074	PIN, clevis	1	

FIG. 18 REAR SUSPENSION

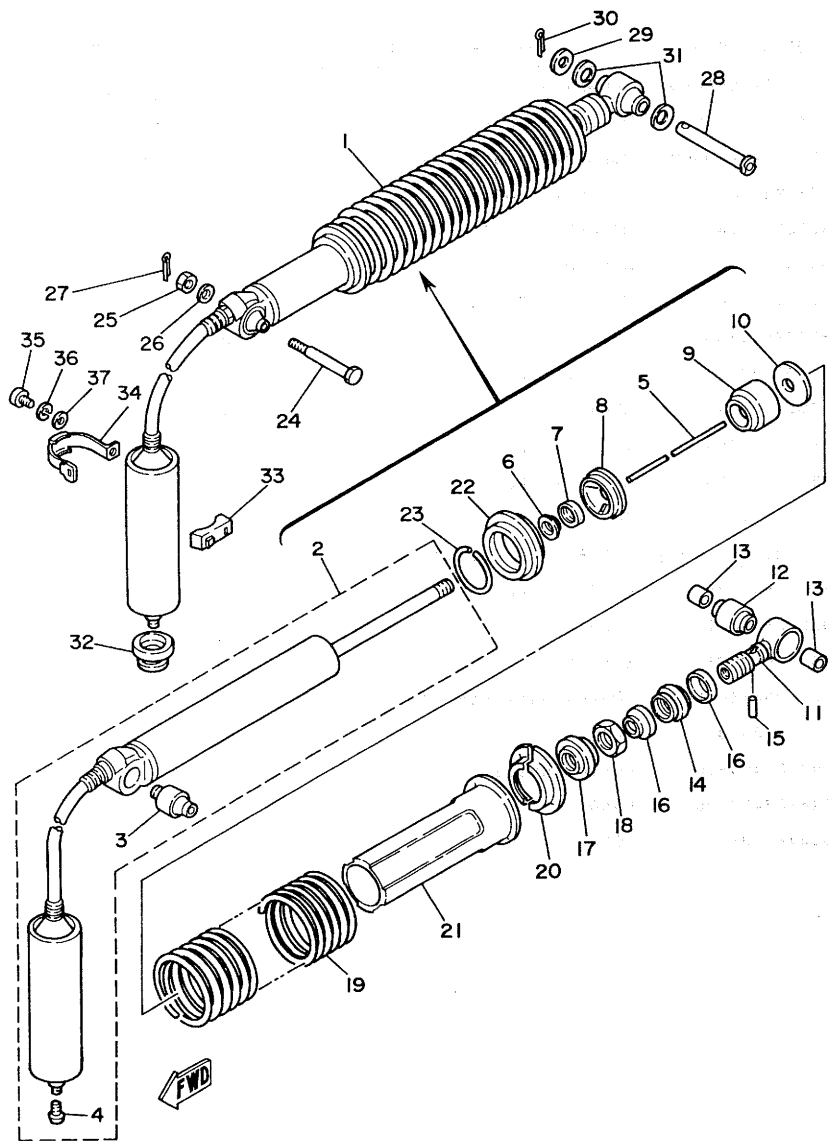

REF. NO.	PART NO.	DESCRIPTION	Q'TY	REMARKS
29	92901-12600	WASHER, Plate	1	
30	91401-30022	PIN, cotter	1	
31	1W1-22128-00	COVER, thrust 1	2	
32	90480-22263	GROMMET	1	
33	3R4-22261-00	DAMPER, sub tank	1	
34	3R4-22262-00	HOLDER, sub tank	1	
35	92502-06016	SCREW, Pan head	1	
36	92902-06100	WASHER, sPring	1	
37	92902-06600	WASHER	1	

FIG. 19 STEERING

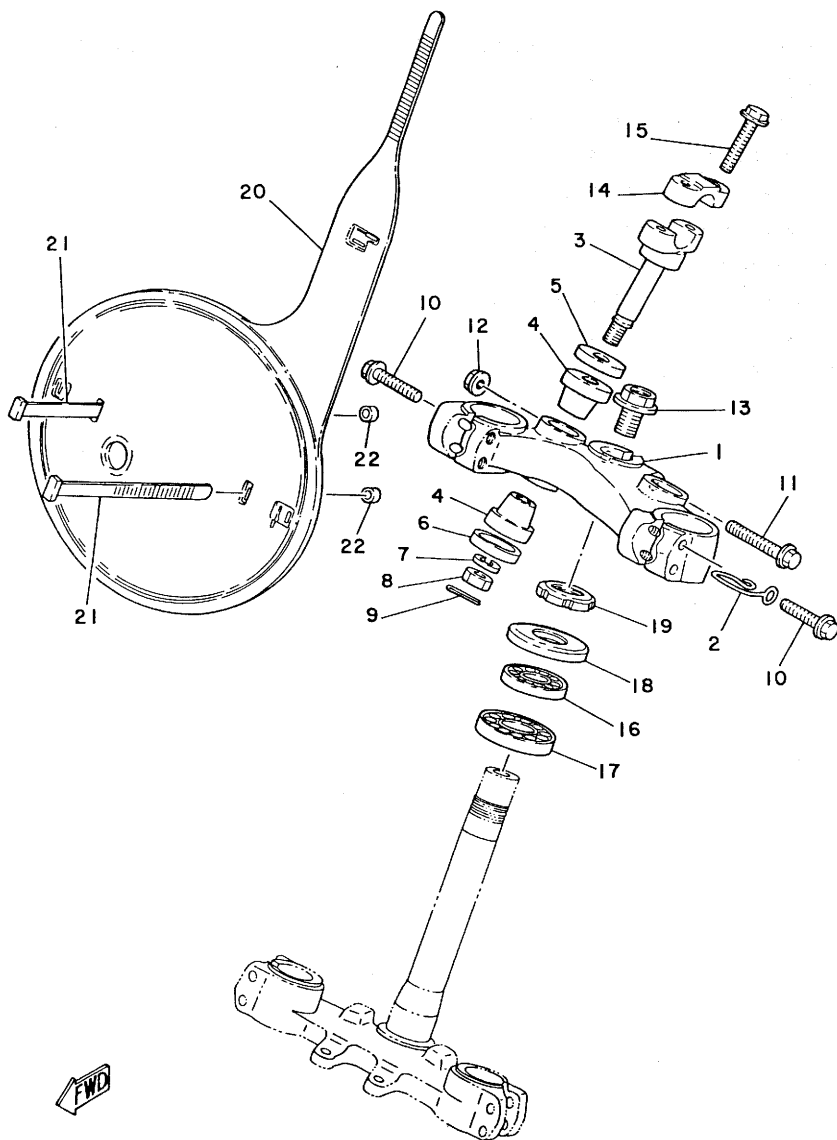

REF. NO.	PART NO.	DESCRIPTION	Q'TY	REMARKS
1	3R4-23435-00-98	CROWN, handle	1	low gloss black
2	3R4-23317-00	HOLDER, cable	1	
3	3R4-23442-00-98	HOLDER, handle lower	2	low gloss black
4	1E6-23434-00	HOLDER, damPer	4	
5	90209-12143	WASHER	2	
6	90209-10195	WASHER	2	
7	92901-10100	WASHER, sPring	2	
8	95302-10700	NUT	2	
9	91402-20018	PIN, cotter	2	
10	95821-08040	BOLT, flange	4	
11	95821-08055	BOLT, flange	1	
12	95701-08100	NUT, flange	1	
13	90105-14136	BOLT, washer based	1	
14	1E6-23441-00-98	HOLDER, handle upper	2	low gloss black
15	95821-08035	BOLT, flange	4	
16	93332-00001	BEARING	1	
17	93332-00008	BEARING	1	
18	1W1-23416-00	COVER, ball race 2	1	
19	90179-25033	NUT	1	
20	3R4-23485-10	PLATE, number	1	
21	2X4-23489-00	BAND	2	
22	90446-09158	HOSE	2	

FIG. 20 FRONT FORK

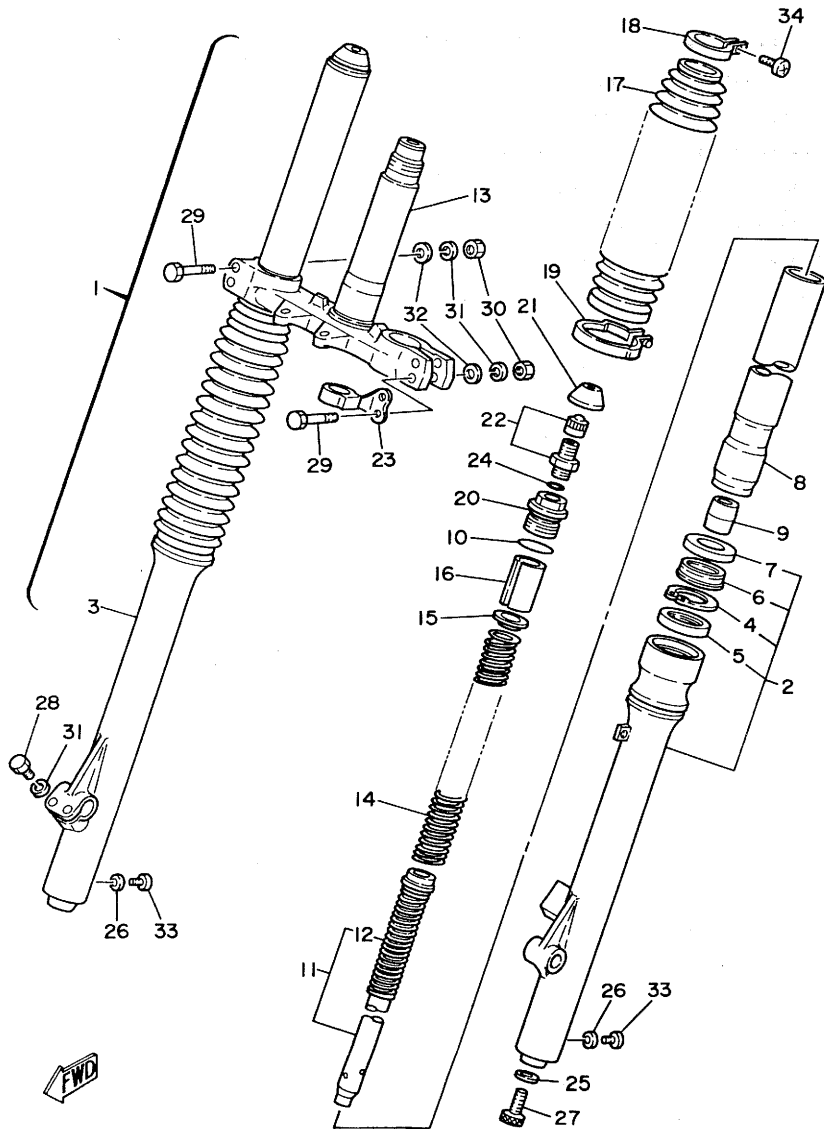

REF. NO.	PART NO.	DESCRIPTION	Q'TY	REMARKS
1	3R4-23101-M0	FRONT FORK ASSY	1	
2	3R4-23126-L0	•TUBE, outer 1	1	
3	3R4-23136-L0	•TUBE, outer 2	1	
4	3R4-23153-00	••RING, snaP	2	
5	1W4-23145-L0	••OIL SEAL	2	
6	3R4-23144-00	••SEAL, dust	2	
7	3R4-23148-00	••COVER, dust seal	2	
8	3R4-23124-L0	•TUBE, inner 1	2	
9	3R4-23173-L0	•SPINDLE, taPer	2	
10	1W4-23114-L0	•GASKET	2	
11	3R4-23170-L0	•CYLINDER COMP., front fork	2	
12	1W4-23151-L0	••SPRING, rebound	2	
13	2X4-23340-L0-33	•UNDER BRACKET COMP.	1	yamaha black
14	3R4-23141-L0	•SPRING, front fork	2	
15	1W4-23142-L0	•SEAT, sPring uPPer	2	
16	1W4-23118-L0	•SPACER	2	
17	3R4-23191-M0	•BOOT	2	
18	341-92090-60	•BAND, boot	2	
19	1W4-23489-L0	•BAND	2	
20	1W4-23111-L1	•BOLT, caP	2	
21	1W1-23168-L0	•WASHER, outer tube	2	
22	509-23190-L0	•AIR VALVE COMP.	2	
23	3R4-23389-00	•GUIDE, cable	1	
24	509-23163-L0	•O-RING	2	
25	2R8-23158-L0	•GASKET	2	
26	122-23129-00	•GASKET, drain Plug	2	
27	3R4-23181-L0	•BOLT, hexaGon socket head	2	
28	1W4-23128-L0	•BOLT, axle holder	2	

FIG. 20 FRONT FORK

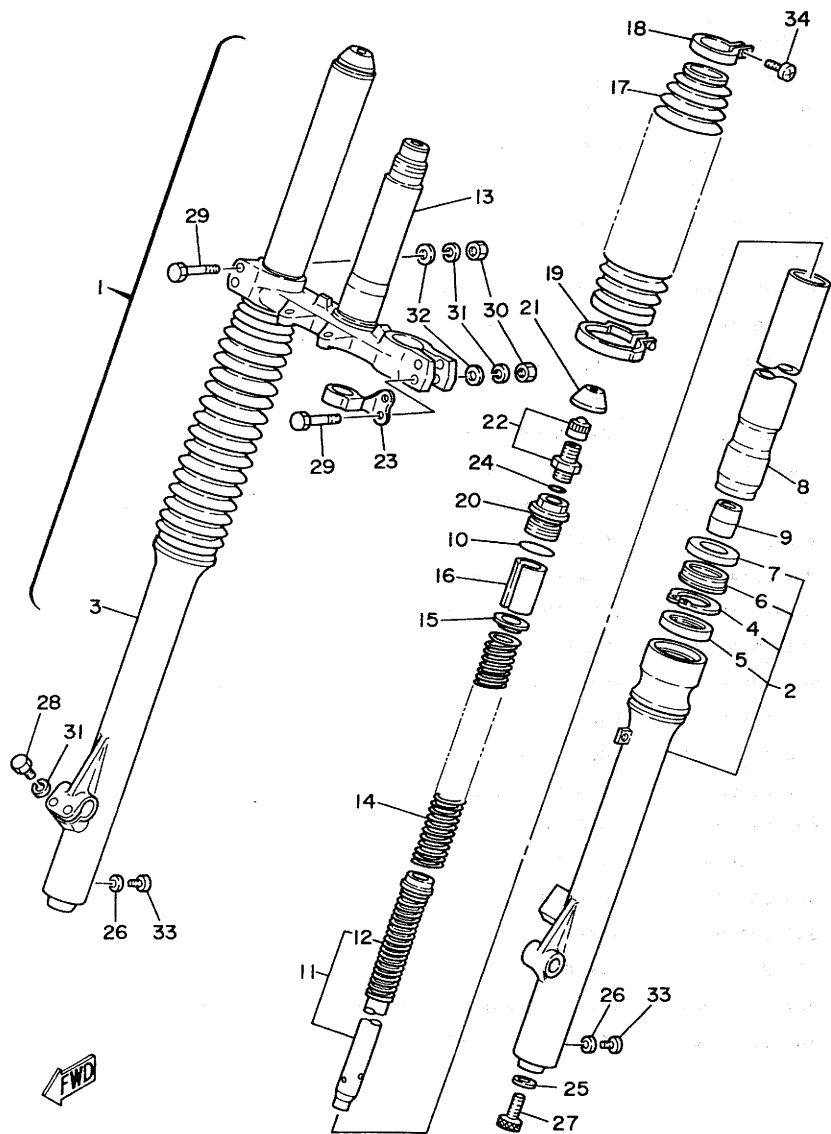

REF. NO.	PART NO.	DESCRIPTION	Q'TY	REMARKS
29	90109-08397	•BOLT	4	
30	95311-08600	•NUT	4	
31	92901-08100	•WASHER, sPring	6	
32	90201-08544	•WASHER, Plate	4	
33	122-23119-01	•PLUG, drain	2	
34	509-23194-L0	•SCREW, boot band	2	

C13

FIG. 21 FUEL TANK

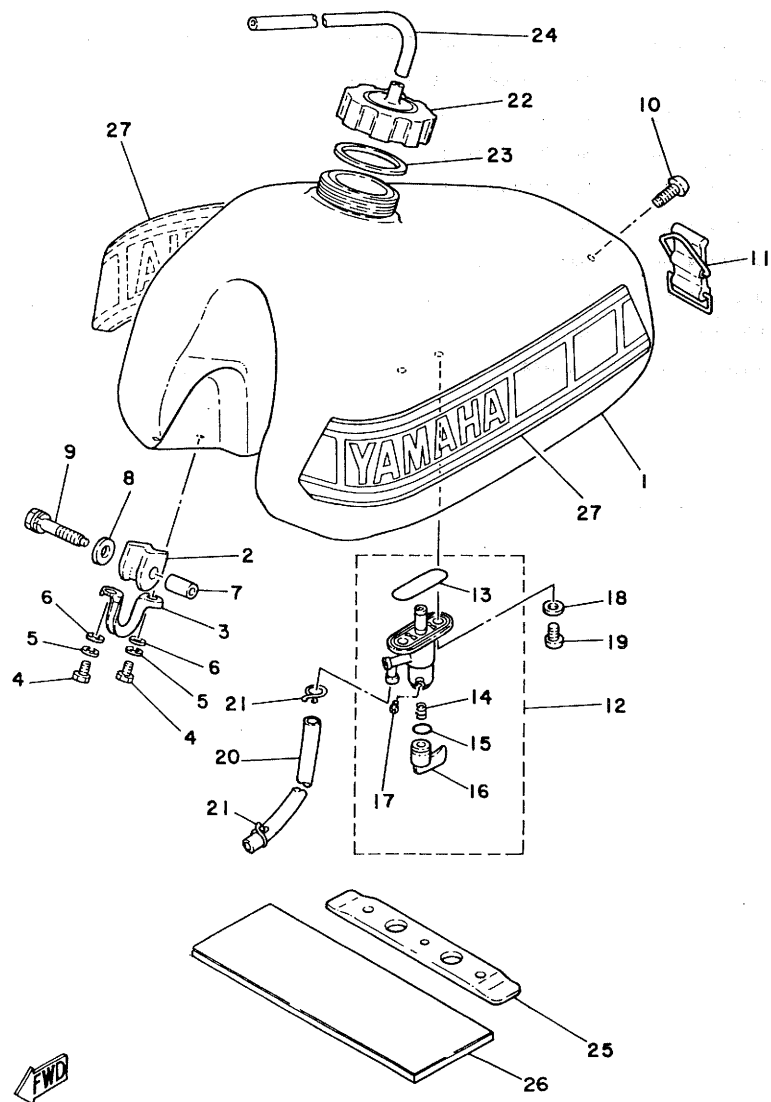

REF. NO.	PART NO.	DESCRIPTION	Q'TY	REMARKS
1	3R5-24110-10	FUEL TANK COMP.	1	clean white
2	1W1-24182-01	DAMPER, locatin8 2	2	
3	1W1-24144-01	HOLDER, damPer	2	
4	97301-06012	BOLT	4	
5	92901-06100	WASHER, sPrin8	4	
6	92901-06600	WASHER, Plate	4	
7	90387-07393	COLLAR	2	
8	90201-06407	WASHER, Plate	2	
9	90119-06022	BOLT, with washer	2	
10	98902-06018	SCREW, bind	1	
11	3R3-24173-00	BAND, tank fittin8 1	1	
12	2K5-24500-00	FUEL COCK ASSY 1	1	
13	214-24512-00	.GASKET	1	
14	1A0-24529-01	.SPRING	1	
15	1A0-24512-00	.O-RING	1	
16	1A0-24524-01	.LEVER, cock	1	
17	619-24535-00	.SCREW, lever fittin8	1	
18	90202-06010	WASHER, Plate	2	
19	90149-06011	SCREW	2	
20	90445-11182	HOSE	1	
21	90467-10008	CLIP	2	
22	1W1-24611-00	BODY, caP	1	
23	1W1-24612-00	GASKET, caP	1	
24	90445-09300	HOSE	1	
25	3R4-24181-00	DAMPER, locatin8 1	1	
26	1W1-24183-00	DAMPER, locatin8 3	1	
27	3R5-24240-30	GRAPHIC SET	1	

FWD

FIG. 22 SEAT

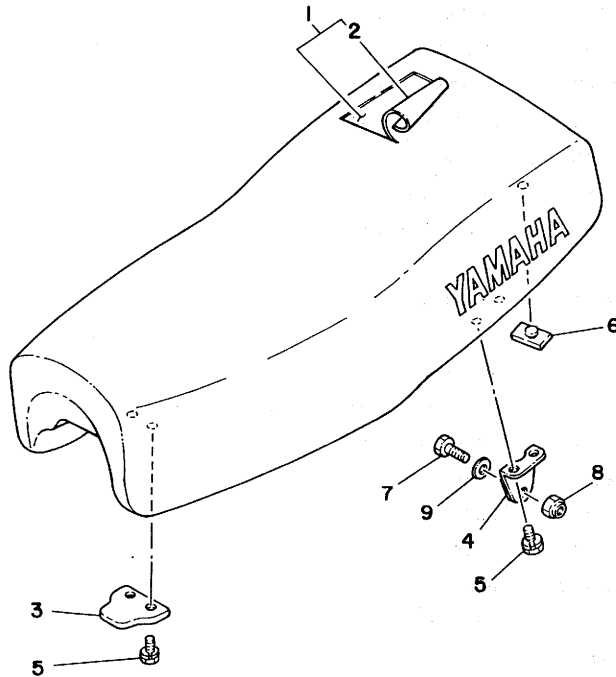

REF. NO.	PART NO.	DESCRIPTION	Q'TY	REMARKS
1	3R4-W2473-00	SEMI-DOUBLE SEAT ASSY	1	
2	3R4-24771-00	COVER, semi-double seat	1	
3	1M1-24748-00	BRACKET, seat	1	
4	1W1-24738-00	BRACKET, seat	2	
5	90101-06304	BOLT	6	
6	509-24724-00	DAMPER, seat	2	
7	97302-06035	BOLT	2	
8	95601-06100	NUT, u	2	
9	92902-06200	WASHER	2	



FIG. 23 FRONT WHEEL

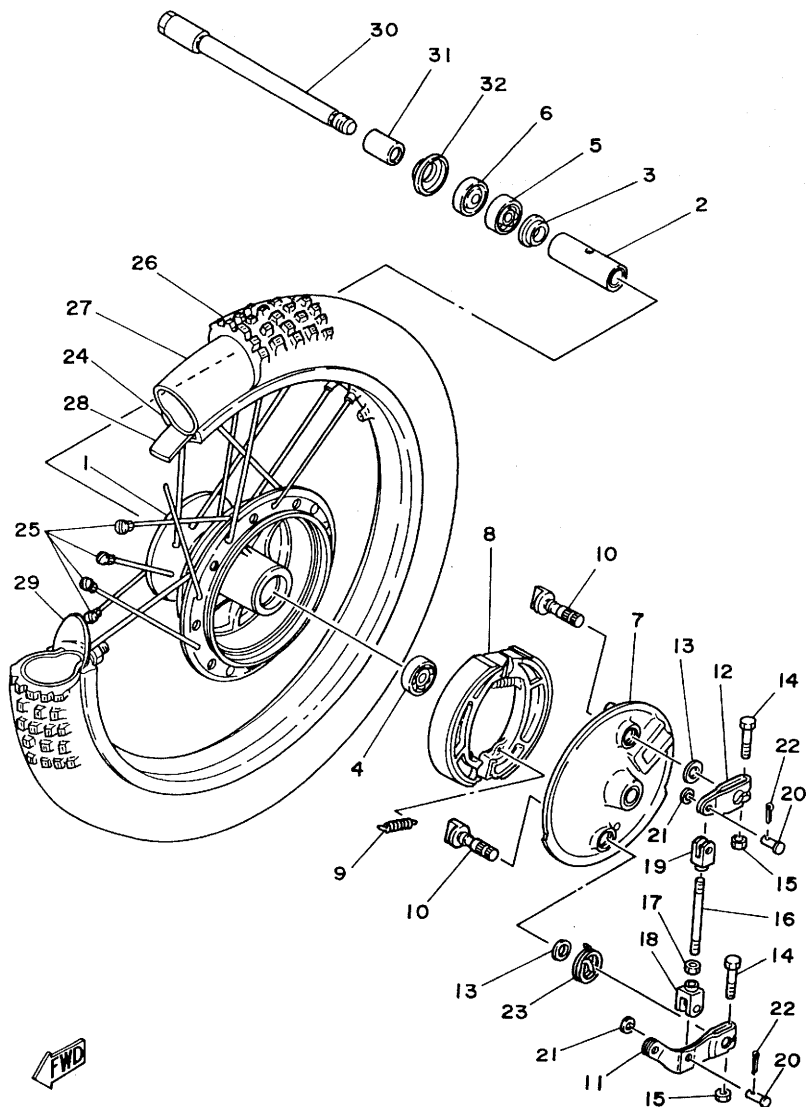

REF. NO.	PART NO.	DESCRIPTION	Q'TY	REMARKS
1	1K7-25111-10-98	HUB, front	1	low gloss black
2	90560-15116	SPACER	1	
3	146-25116-00	FLANGE, sPacer 2	1	
4	93306-20203	BEARING (B6202RS)	1	
5	93306-20205	BEARING (B6202)	1	
6	93102-20009	OIL SEAL	1	
7	3R5-25121-00-98	PLATE, brake shoe	1	low gloss black
8	3R5-25130-00	BRAKE SHOE COMP.	2	
9	90506-16036	SPRING, tension	2	
10	322-25151-00	CAMSHAFT	2	
11	3R5-25155-00	LEVER, camshaft 1	1	
12	3R5-25156-00	LEVER, camshaft 2	1	
13	137-25159-00	SEAL, camshaft	2	
14	90101-06278	BOLT	2	
15	95301-06600	NUT	2	
16	3R5-25161-00	ROD, connecting	1	
17	95301-06700	NUT	1	
18	3R5-25163-00	END, rod 1	1	
19	3R5-25164-00	END, rod 2	1	
20	90240-06006	PIN, clevis	2	
21	92901-06200	WASHER, Plain	2	
22	91401-20012	PIN, cotter	2	
23	90508-20425	SPRING, torsion	1	
24	94416-21234	RIM (1.60-21)	1	
25	2W6-25104-01	SPOKE SET, front	1	
26	94130-21554	TIRE (3.00-21)	1	
27	94227-21123	TUBE (2.75-21)	1	
28	94330-21084	BAND, rim (3.00-21)	1	

D2

FIG. 23 FRONT WHEEL

REF. NO.	PART NO.	DESCRIPTION	Q'TY	REMARKS
29	2J5-25394-00	SPACER, bead	1	
30	3R4-25181-00	AXLE, wheel	1	
31	90387-15535	COLLAR	1	
32	322-25118-00	COVER, hub dust	1	

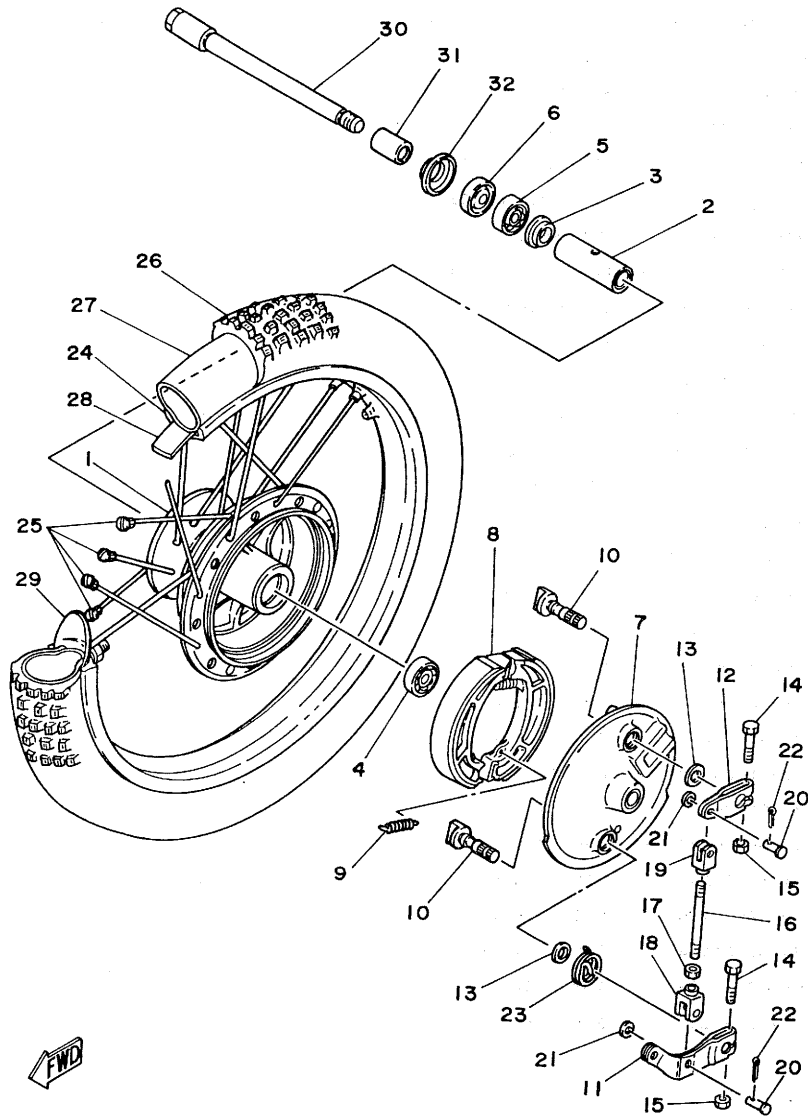

FWD

D3

FIG. 24 REAR WHEEL

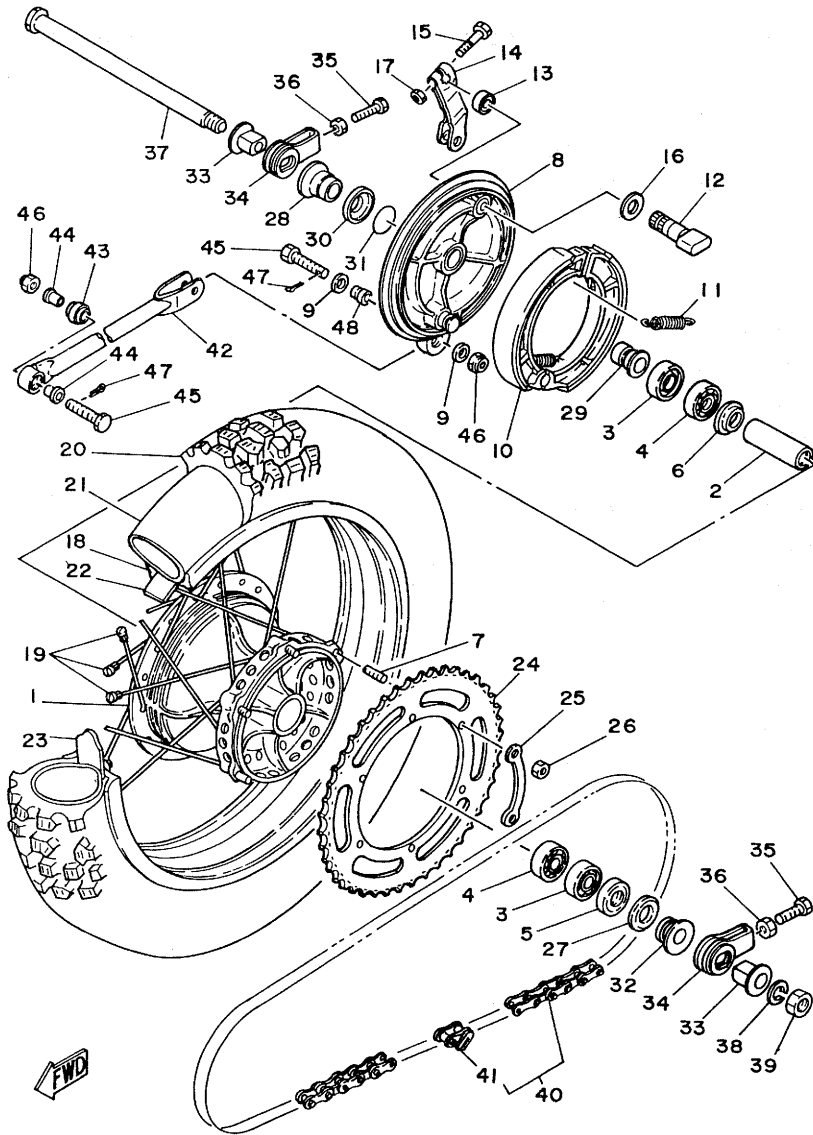

REF. NO.	PART NO.	DESCRIPTION	Q'TY	REMARKS
1	3R5-25311-00-98	HUB, rear	1	low gloss black
2	483-25317-01	SPACER, bearing	1	
3	93306-20310	BEARING (B6203RS)	2	
4	93306-20316	BEARING (B6203)	2	
5	93102-25030	OIL SEAL	1	
6	483-25315-00	FLANGE, spacer	1	
7	90116-08218	BOLT, stud	6	
8	2X4-25321-00-98	PLATE, brake shoe	1	low gloss black
9	93104-11056	OIL SEAL	2	
10	2X4-25330-00	BRAKE SHOE COMP.	2	
11	90507-20002	SPRING, tension	2	
12	1E2-25151-00	CAMSHAFT	1	
13	148-25359-00	SEAL, camshaft	1	
14	2X4-25355-00	LEVER, camshaft	1	
15	90101-06278	BOLT	1	
16	148-25353-00	SHIM, camshaft	1	
17	95301-06600	NUT	1	
18	94425-18218	RIM (2.50-18)	1	
19	2X5-25304-01	SPOKE SET, rear	1	
20	94151-18553	TIRE (5.10-18)	1	
21	94251-18150	TUBE (5.10-18)	1	
22	94340-18086	BAND, rim (4.00-18)	1	
23	2X5-25394-00	SPACER, bead	2	
24	431-25446-00	SPROCKET, driven (46T)	1	UR STD
	431-25444-00	SPROCKET, driven (44T)	1	UR
	431-25448-03	SPROCKET, driven (48T)	1	UR
	431-25450-04	SPROCKET, driven (50T)	1	UR
25	583-25412-00	WASHER	3	

FIG. 24 REAR WHEEL

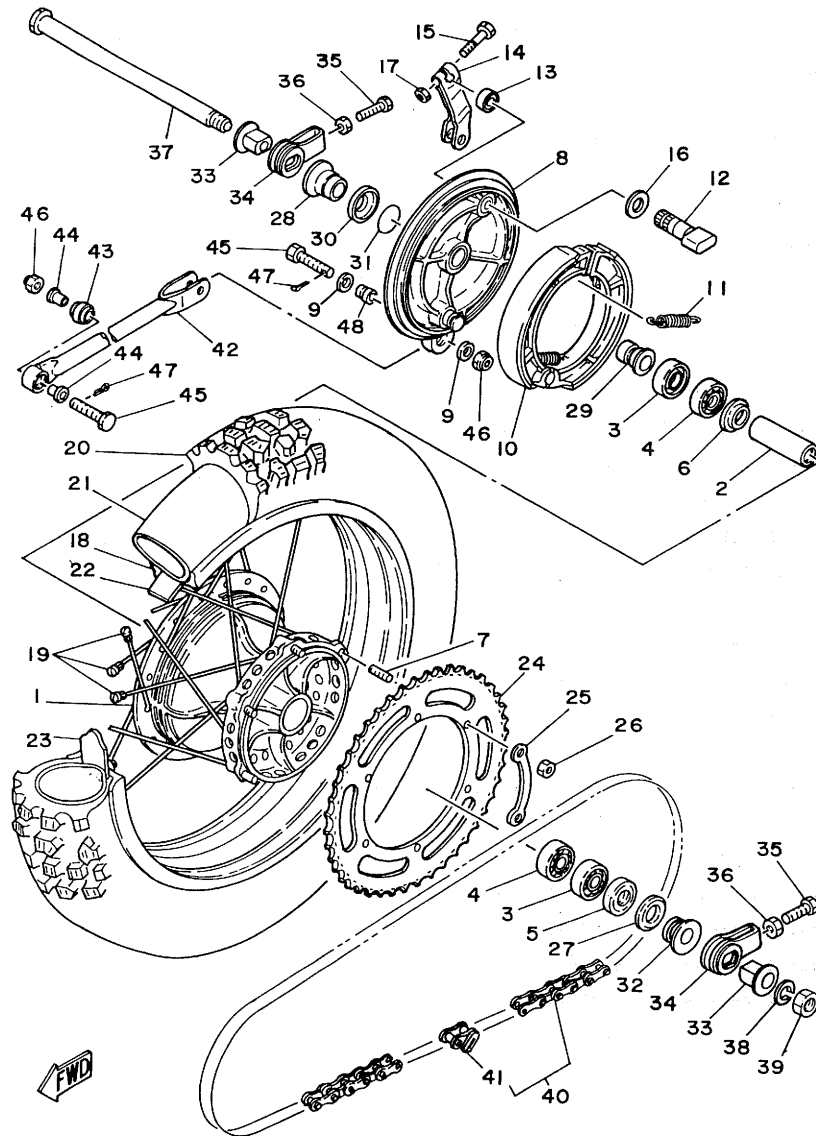

REF. NO.	PART NO.	DESCRIPTION	Q'TY	REMARKS
26	90170-08193	NUT	6	
27	431-25367-00	COVER, hub dust	1	
28	90387-17779	COLLAR	1	
29	90387-17700	COLLAR	1	
30	275-25327-00	COVER, Plate	1	
31	93210-31114	O-RING	1	
32	90387-17780	COLLAR	1	
33	90381-17027	BUSH, solid	2	
34	2K8-25388-00	PULLER, chain 1	2	
35	90101-08475	BOLT	2	
36	95301-08700	NUT	2	
37	3R4-25381-00	AXLE, wheel	1	
38	92901-16100	WASHER, sPring	1	
39	90170-16177	NUT	1	
40	94585-20108	CHAIN, drive (DID520DS 108L)	1	
41	94685-20001	JOINT, chain	1	
42	3R5-25371-00	BAR, tension	1	
43	93399-99904	BEARING	1	
44	90387-080A8	COLLAR	2	
45	90102-08034	BOLT, with hole	2	
46	95611-08100	NUT, u	2	
47	91401-20015	PIN, cotter	2	
48	90387-08699	COLLAR	1	

D5

FIG. 25 HANDLEBAR•CABLE

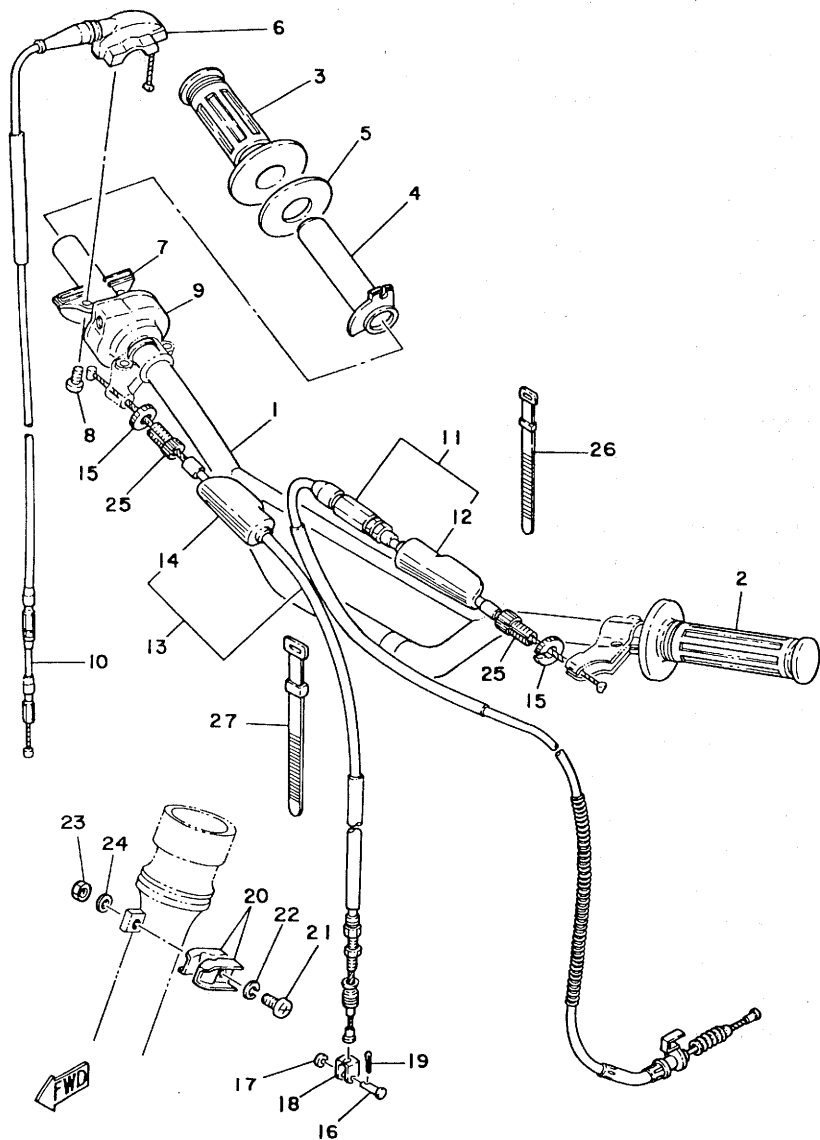

REF. NO.	PART NO.	DESCRIPTION	Q'TY	REMARKS
1	3R4-26111-00	HANDLEBAR	1	
2	583-26241-00	GRIP (L.H)	1	
3	583-26242-00	GRIP (R.H)	1	
4	431-26243-00	TUBE, throttle guide	1	
5	1W1-26249-00	RING, leaf	1	
6	431-26281-01-98	CAP, grip upper	1	low gloss black
7	431-26282-01-98	CAP, grip lower	1	low gloss black
8	98501-05016	SCREW, Pan head	2	
9	3R8-26287-00	COVER, cap grip	1	
10	2K8-26311-01	CABLE, throttle 1	1	
11	3R4-26335-00	CABLE, clutch	1	
12	382-26372-01	COVER, handle lever	1	
13	3R8-26341-00	CABLE, brake	1	
14	382-26372-01	COVER, handle lever	1	
15	90179-08148	NUT	2	
16	90240-08012	PIN, clevis	1	
17	90201-08083	WASHER, plate	1	
18	156-26347-00	JOINT, cable	1	
19	91401-20012	PIN, cotter	1	
20	90462-14055	CLAMP	2	
21	92501-06025	SCREW, Pan head	1	
22	92901-06100	WASHER, spring	1	
23	95301-06600	NUT	1	
24	92901-06600	WASHER, plate	1	
25	90123-08046	BOLT	2	
26	256-83936-00	BAND, switch cord	1	
27	437-83936-10	BAND, switch cord	1	

FIG. 26 STAND•FOOTREST

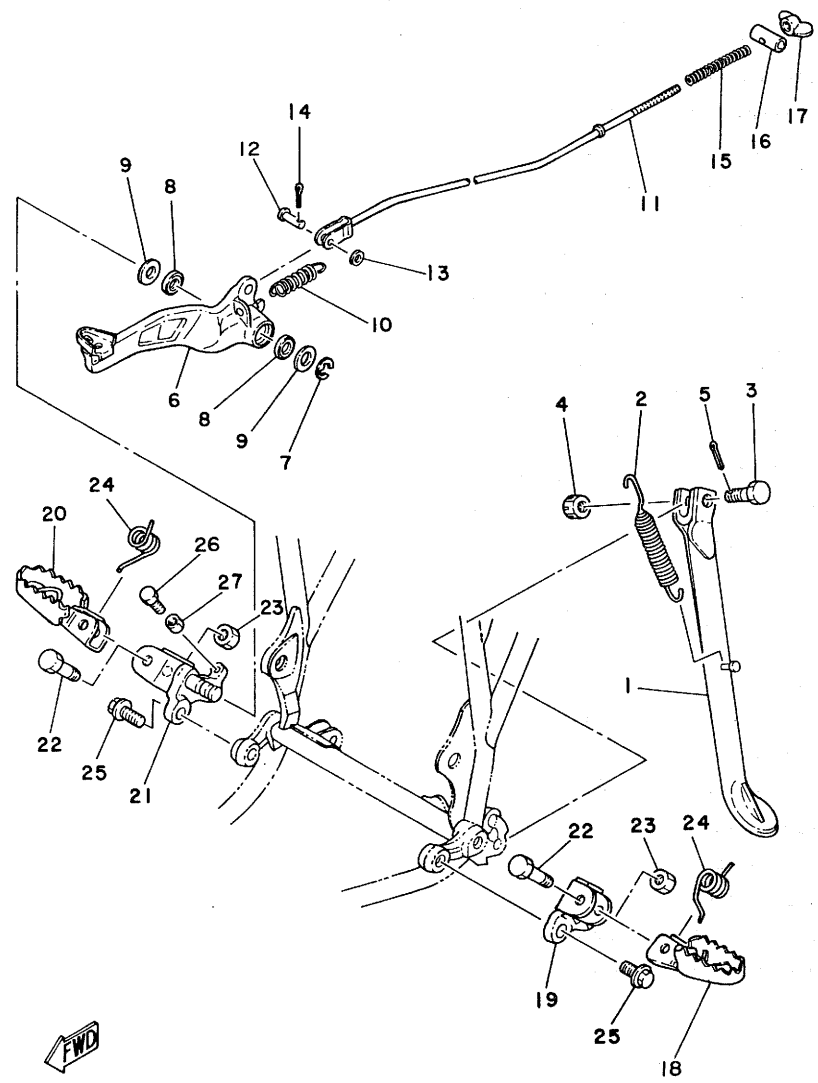

REF. NO.	PART NO.	DESCRIPTION	Q'TY	REMARKS
1	3R4-27311-00-33	STAND, side	1	yamaha black
2	90507-29008	SPRING, tension	1	
3	90102-10006	BOLT, with hole	1	
4	95302-10900	NUT, slotted	1	
5	91401-20025	PIN, cotter	1	
6	3R4-27200-00	PEDAL, brake	1	
7	93430-10015	CIRCLIP	1	
8	93109-14021	OIL SEAL	2	
9	90201-14536	WASHER, Plate	2	
10	90506-20192	SPRING, tension	1	
11	2X4-27231-01	ROD, brake	1	
12	90240-06040	PIN, clevis	1	
13	92901-06200	WASHER, Plain	1	
14	91401-20012	PIN, cotter	1	
15	90501-10245	SPRING, comPression	1	
16	90249-12008	PIN	1	
17	90175-06013	NUT, wing	1	
18	3R4-27411-00-33	FOOTREST 1	1	yamaha black
19	2X4-27412-00	BRACKET, footrest 1	1	
20	3R4-27421-00-33	FOOTREST 2	1	yamaha black
21	2X4-27422-00	BRACKET, footrest 2	1	
22	90101-08428	BOLT	2	
23	95601-08100	NUT, u	2	
24	90508-20023	SPRING, torsion	2	
25	90105-12096	BOLT, washer based	4	
26	97301-06020	BOLT	1	
27	95301-06700	NUT	1	

D7

FIG. 27 ELECTRICAL 1

REF. NO.	PART NO.	DESCRIPTION	Q'TY	REMARKS
1	1M2-82310-40	IGNITION COIL ASSY	1	
2	92501-06025	SCREW, Pan head	2	
3	92901-06100	WASHER, sPring	2	
4	90462-05005	CLAMP	1	
5	3R0-82370-20	PLUG CAP ASSY	1	UR
	8E7-82370-11	PLUG CAP ASSY	1	UR with noise suppressor
6	437-83936-00	BAND, switch cord	2	

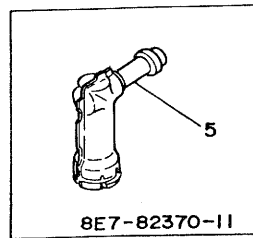
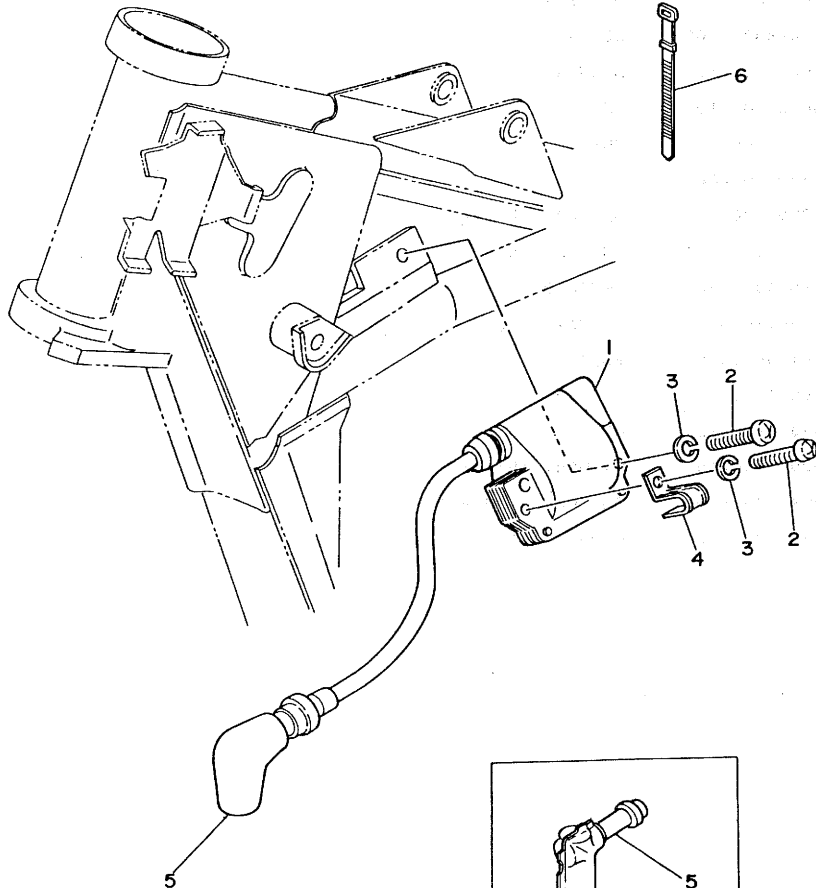

FWD

D8

FIG. 28 HANDLE SWITCH LEVER

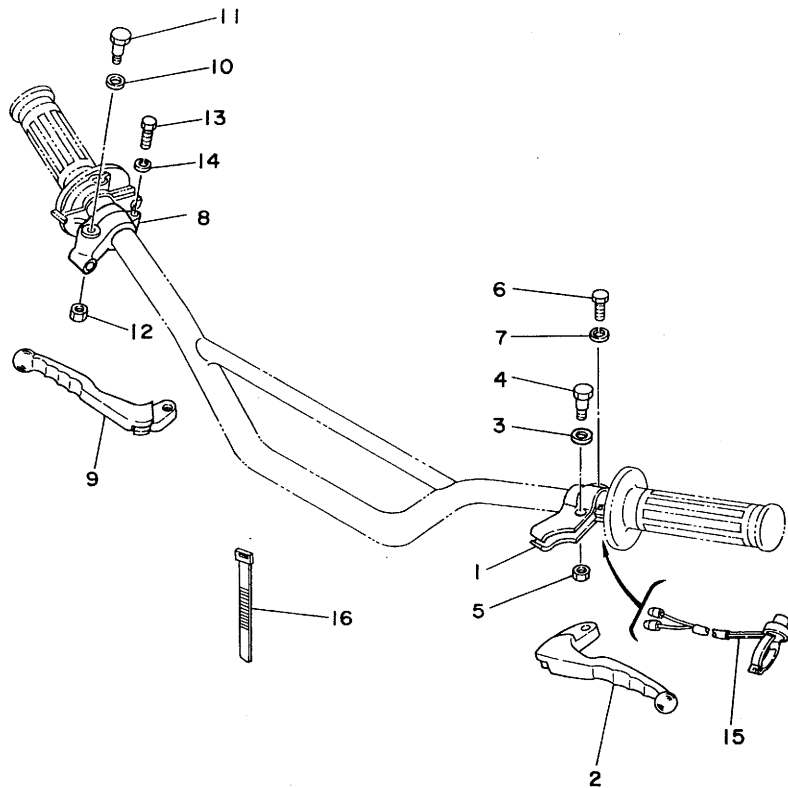

REF. NO.	PART NO.	DESCRIPTION	Q'TY	REMARKS
1	461-82911-00	HOLDER, lever 1	1	
2	2K6-83912-00	LEVER 1	1	
3	90201-08083	WASHER, Plate	1	
4	90109-06410	BOLT	1	
5	95601-06100	NUT, u	1	
6	97301-06022	BOLT	1	
7	92901-06100	WASHER, sPring	1	
8	516-82921-30	HOLDER, lever 2	1	
9	2K6-83922-00	LEVER 2	1	
10	90201-08083	WASHER, Plate	1	
11	90109-06410	BOLT	1	
12	95601-06100	NUT, u	1	
13	97301-06022	BOLT	1	
14	92901-06100	WASHER, sPring	1	
15	3R4-83976-00	SWITCH, handle 1	1	
16	437-83936-00	BAND, switch cord	2	

ALTERNATE PARTS

FIG. 29 ALTERNATE (CHASSIS)

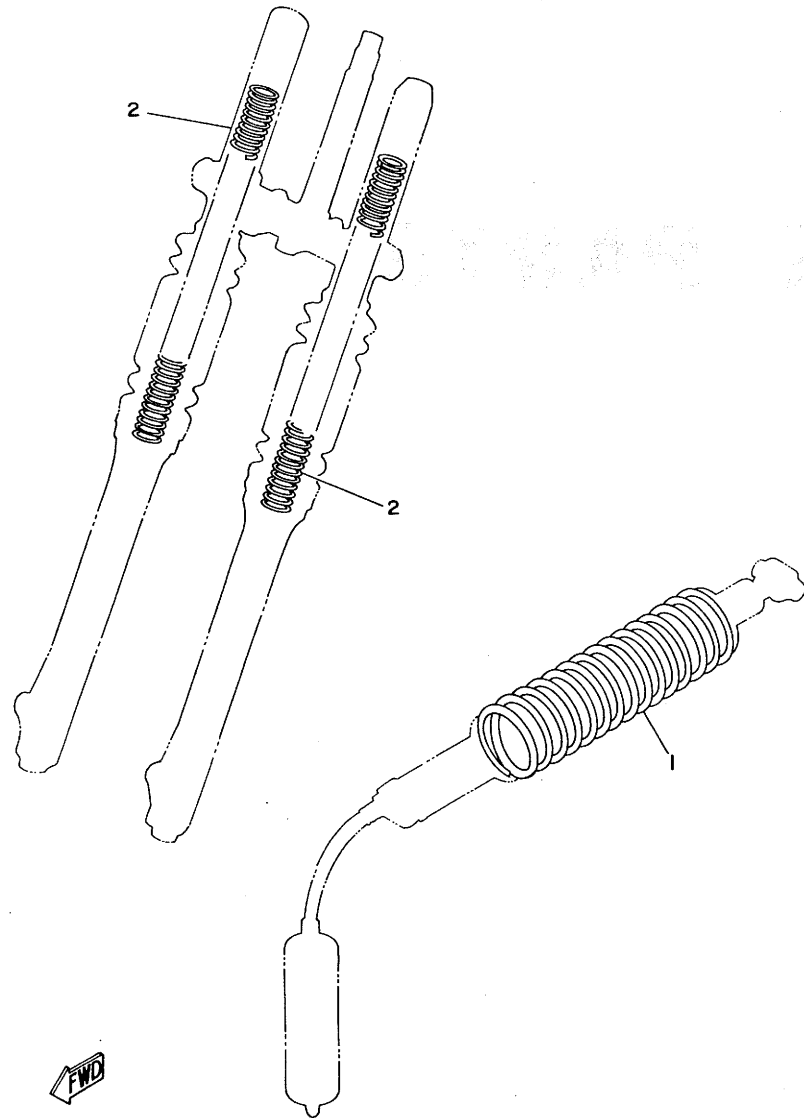

REF. NO.	PART NO.	DESCRIPTION	Q'TY	REMARKS
1	3R4-22212-10	SPRING	1	UR soft
	3R4-22212-20	SPRING	1	UR hard
2	3R4-23141-10	SPRING, front fork	2	UR soft
	3R4-23141-20	SPRING, front fork	2	UR hard

REPAIR KIT

FIG. 30 REPAIR KIT

REF. NO.	PART NO.	DESCRIPTION	Q'TY	REMARKS	REF. NO.	PART NO.	DESCRIPTION	Q'TY	REMARKS
1	3R5-11630-00	PISTON ASSY (STD)	1		28	3R5-11681-00	•PIN, crank 1	1	
2	3R5-11631-00-94	•PISTON (STD)	1	UR	29	90209-25085	•WASHER	2	
	3R5-11631-00-96	•PISTON (STD)	1	UR	30	93310-42541	•BEARING, cylindrical	1	
3	3R5-11601-00	•PISTON RING SET (STD)	1		31	93310-418E9	•BEARING, cylindrical	1	
4	1W4-11633-00	•PIN, Piston	1		32	3R5-W0001-00	GASKET KIT	1	
5	93450-19052	•CIRCLIP	2		33	3R5-11181-00	•GASKET, cylinder head 1	1	
6	3R5-11630-10	PISTON ASSY (1ST O/S)	1		34	3R5-11351-00	•GASKET, cylinder	1	
7	3R5-11635-00	•PISTON (1ST O/S 0.25MM)	1		35	2K7-13621-00	•GASKET, valve seat	1	
8	3R5-11601-10	•PISTON RING SET (1ST O/S)	1		36	363-14184-00	•GASKET, float chamber	1	
9	1W4-11633-00	•PIN, Piston	1		37	3R5-15451-00	•GASKET, crankcase cover	1	
10	93450-19052	•CIRCLIP	2		38	3R4-15462-00	•GASKET, crankcase cover 3	1	
11	3R5-11630-20	PISTON ASSY (2ND O/S)	1		39	93210-14104	•O-RING	1	
12	3R5-11636-00	•PISTON (2ND O/S 0.50MM)	1		40	90430-06016	•GASKET	1	
13	3R5-11601-20	•PISTON RING SET (2ND O/S)	1		41	90430-12038	•GASKET	1	
14	1W4-11633-00	•PIN, Piston	1		42	93210-29282	•O-RING	1	
15	93450-19052	•CIRCLIP	2		43	2K7-W0003-00	OIL SEAL KIT	1	
16	3R5-11630-30	PISTON ASSY (3RD O/S)	1		44	93103-30092	•OIL SEAL	1	
17	3R5-11637-00	•PISTON (3RD O/S 0.75MM)	1		45	93103-40091	•OIL SEAL	1	
18	3R5-11601-30	•PISTON RING SET (3RD O/S)	1		46	93102-17004	•OIL SEAL	1	
19	1W4-11633-00	•PIN, Piston	1		47	93102-32136	•OIL SEAL	1	
20	93450-19052	•CIRCLIP	2		48	93101-12004	•OIL SEAL	1	
21	3R5-11630-40	PISTON ASSY (4TH O/S)	1		49	93109-20014	•OIL SEAL	1	
22	3R5-11638-00	•PISTON (4TH O/S 1.00MM)	1						
23	3R5-11601-40	•PISTON RING SET (4TH O/S)	1						
24	1W4-11633-00	•PIN, Piston	1						
25	93450-19052	•CIRCLIP	2						
26	3R5-11650-00	CONNECTING ROD ASSY	1						
27	3R5-11651-00	•ROD, connecting	1						

INDEX

NUMERICAL INDEX

NUMERICAL INDEX

PART NO.	REF. NO.	PART NO.	REF. NO.	PART NO.	REF. NO.	PART NO.	REF. NO.	PART NO.	REF. NO.	PART NO.	REF. NO.
3R5-W0001-00	30-32	3R5-11681-00	2- 9	509-14274-00	5-28	3R5-17131-00	11- 6	3R5-22153-00	17-15	3R4-23170-L0	20-11
2K7-W0003-00	30-43		30-28	3R4-14401-00	4-11	3R5-17141-00	11- 3	2K6-22178-00	14-17	3R4-23173-L0	20- 9
3R4-W2473-00	22- 1	137-13115-00	7-19	3R4-14450-00	4-14	3R5-17151-00	11- 8	2X4-22179-00	17-14	3R4-23181-L0	20-27
3R5-11111-00	1- 1	3R4-13565-00	4- 7			3R5-17211-00	11-20	2X4-22199-00	17-16	509-23190-L0	20-22
3R5-11181-00	1- 2	3R5-13610-00	4- 1	1W4-14457-00	4-12	3R5-17221-00	11-13	3R4-22210-00	18- 1	3R4-23191-M0	20-17
	30-33	3R5-13613-00	4- 2			3R5-17231-00	11-18	3R4-22212-00	18-19	509-23194-L0	20-34
3R5-11311-00	1- 6	2X5-13616-00	4- 3	3R5-14610-00	6- 1	2X5-17241-00	11-19	3R4-22212-10	29- 1	3R4-23317-00	19- 2
3R5-11351-00	1- 7	2K7-13621-00	4- 6	3R4-14613-00	6- 2	3R5-17251-00	11-16	3R4-22212-20	29- 1	2X4-23340-L0-33	20-13
	30-34		30-35	3R5-14619-00	6- 9	3R5-17411-00	11- 1	3R4-22213-00	18-17	3R4-23389-00	20-23
3R5-11400-00	2- 6	3R5-14101-00	5- 1	565-14747-00	6-12	3R5-17421-00	11-12	3R4-22214-00	18-20	1W1-23416-00	19-18
3R5-11412-00	2- 7	510-14112-30	5-27	3R5-14753-00	6-11	1W4-17461-30	11-27	1W1-22216-00	18- 3	1E6-23434-00	19- 4
3R5-11422-00	2- 8	510-14115-00	5-31	565-14771-00	6-16	1W4-17461-40	11-27	3R4-22221-01	18-16	3R4-23435-00-98	19- 1
3R5-11601-00	2- 2	239-14116-16	5-33	3R4-14781-02	6- 4	1W4-17461-50	11-27	3R4-22223-00	18-22	1E6-23441-00-98	19-14
	30- 3	2A0-14122-00	5-25	3R5-15111-00	7- 1	3R4-18101-01	13- 1	3R4-22224-00	18-21	3R4-23442-00-98	19- 3
3R5-11601-10	2- 2	152-14123-00	5-23	3R4-15113-00	7-17	3R5-18111-00	13- 2	3R4-22226-00	18-12	3R4-23485-10	19-20
	30- 8	363-14131-00	5-17	3R4-15118-00	7-15	3R4-18140-00	12- 7	3R4-22228-00	18-10	1W4-23489-L0	20-19
3R5-11601-20	2- 2	127-14134-00	5-22	3R5-15121-00	7- 9	1W1-18177-00	12- 9	3R4-22261-00	18-33	2X4-23489-00	19-21
	30-13	156-14135-00	5-41	1G8-15362-00	8-11	3R4-18185-00	12- 2	3R4-22262-00	18-34	3R5-24110-10	21- 1
3R5-11601-30	2- 2	509-14136-00	5-35	3R4-15381-00	7-13	3R5-18511-00	12-10	3R4-22401-00	18- 2	1W1-24144-01	21- 3
	30-18	164-14137-00	5-34	3R4-15383-00	7- 6	3R5-18512-00	12-11	3R4-22409-00	18-11	3R3-24173-00	21-11
3R5-11601-40	2- 2	363-14137-00	5-21	3R5-15411-00	8- 1	3R5-18513-00	12-12	3R4-22472-00	18- 8	3R4-24181-00	21-25
	30-23	353-14138-00	5-37	3R4-15421-00	8- 4	3R4-18531-00	12-14	3R4-22473-00	18- 7	431-24181-00	16- 7
3R5-11630-00	30- 1	510-14141-48	5- 5	3R4-15431-00	8- 8	3R4-18535-00	12-15	3R4-22475-00	18- 6	1W1-24182-01	21- 2
3R5-11630-10	30- 6	193-14142-50	5- 4	3R5-15451-00	8- 2	3R5-18540-00	12- 1	3R4-22489-00	18- 5	1W1-24183-00	21-26
3R5-11630-20	30-11	137-14143-76	5- 6		30-37	3R4-18561-00	12- 3	1W1-22493-00	18- 9	156-24186-00	6-14
3R5-11630-30	30-16	137-14143-78	5- 6	3R4-15462-00	8- 9	3R4-21110-00-33	14- 1	3R4-22497-00	18-14	3R5-24240-30	21-27
3R5-11630-40	30-21	137-14143-80	5- 6		30-38	3R4-2139W-00	14-23	3R4-23101-M0	20- 1	2K5-24500-00	21-12
3R5-11631-00-94	2- 1	3R4-14146-00	5-29	2K7-15618-00	9-17	3R4-21415-00	14- 2	1W4-23111-L1	20-20	1A0-24512-00	21-15
	30- 2	558-14147-00	5-32	3R4-15620-00	9-11	3R5-21425-00	14- 4	1W4-23114-L0	20-10	214-24512-00	21-13
3R5-11631-00-96	2- 1	8F2-14147-00	5-18	3R4-15621-01	9-12	2K7-2148A-00	14-16	1W4-23118-L0	20-16	1A0-24524-01	21-16
	30- 2	2X8-14153-00	5-30	3R4-15641-00	9- 2	3R8-21511-00	15- 1	122-23119-01	20-33	1A0-24529-01	21-14
1W4-11633-00	2- 3	3R4-14155-00	5-20	3R4-15651-00	9- 7	3R4-21611-10	15- 6	3R4-23124-L0	20- 8	619-24535-00	21-17
	30- 4	3R4-14158-00	5-24	3R4-15660-00	9- 1	1M1-21621-00	15-14	3R4-23126-L0	20- 2	1W1-24611-00	21-22
	30- 9	127-14161-00	5-19	3R4-15664-00	9- 6	3R4-21629-00	15-10	1W4-23128-L0	20-28	1W1-24612-00	21-23
	30-14	802-14161-00	5-26	3R5-16111-00	10- 1	3R4-21711-10-98	16- 1	122-23129-00	20-26	509-24724-00	22- 6
	30-19	737-14171-00	5-42	3R4-16150-00	10- 7	3R4-2172A-00	16-12	3R4-23136-L0	20- 3	1W1-24738-00	22- 4
	30-24	637-14173-00	5-40			3R4-21721-10-98	16- 8	3R4-23141-L0	20-14	1M1-24748-00	22- 3
3R5-11635-00	2- 1	152-14174-00	5-36	2K7-16154-00	10-15	3R4-21732-00	16-11	3R4-23141-10	29- 2	3R4-24771-00	22- 2
	30- 7	3R4-14181-16	5- 2	2K7-16181-00	10-14	3R5-21737-00	16-21	3R4-23141-20	29- 2	2W6-25104-01	23-25
3R5-11636-00	2- 1	363-14184-00	5- 3	3R5-16300-00	10- 6	3R4-21746-00	16- 9	1W4-23142-L0	20-15	1K7-25111-10-98	23- 1
	30-12		30-12	383-16321-00	10-11	3R8-21746-00	16-10	3R4-23144-00	20- 6	146-25116-00	23- 3
3R5-11637-00	2- 1	2N7-14185-00	5- 7	168-16325-00	10-10	565-21746-00	15-15	1W4-23145-L0	20- 5	322-25118-00	23-32
	30-17	537-14186-00	5- 9	1M1-16351-00	10- 9	3R5-22110-00-35	17- 1	3R4-23148-00	20- 7	3R5-25121-00-98	23- 7
3R5-11638-00	2- 1	363-14190-35	5- 8	3R4-16356-00	10-18	1W1-22128-00	18-31	1W4-23151-L0	20-12	3R5-25130-00	23- 8
	30-22	239-14195-00	5-10	3R5-16357-00	10-24	3R4-22129-00	17- 5	3R4-23153-00	20- 4	1E2-25151-00	24-12
3R5-11650-00	30-26	2K7-14197-00	5-11	3R4-16371-00	10- 8	3R4-22141-00	17-11	2R8-23158-L0	20-25	322-25151-00	23-10
3R5-11651-00	2-10	310-14197-00	5-14	3R4-16380-01	10-29	3R4-22147-00	17-28	509-23163-L0	20-24	3R5-25155-00	23-11
	30-27	737-14261-00	5-39	3R5-17121-00	11- 9	2W6-22151-00	17-10	1W1-23168-L0	20-21	3R5-25156-00	23-12

NUMERICAL INDEX

PART NO.	REF. NO.	PART NO.	REF. NO.	PART NO.	REF. NO.
137-25159-00	23-13	2X4-2811A-00	14-27	90116-12316	1- 9
3R5-25161-00	23-16	1W1-28135-10	14-26	90119-06022	21- 9
3R5-25163-00	23-18	648-45533-00-03	17- 4	90123-08046	25-25
3R5-25164-00	23-19	104-81328-20	3- 9	90149-06011	21-19
3R4-25181-00	23-30	110-81345-21	3-14	90149-08143	10-20
2X5-25304-01	24-19	116-82131-00	3-21	90159-06016	10-13
3R5-25311-00-98	24- 1	1M2-82310-40	27- 1	90170-08193	24-26
483-25315-00	24- 6	3R0-82370-20	27- 5	90170-12181	3-17
483-25317-01	24- 2	8E7-82370-11	27- 5	90170-16111	17-12
2X4-25321-00-98	24- 8	461-82911-00	28- 1	90170-16177	24-39
275-25327-00	24-30	516-82921-30	28- 8	90170-18089	10- 4
2X4-25330-00	24-10	2K6-83912-00	28- 2	90170-20213	18-18
148-25353-00	24-16	2K6-83922-00	28- 9	90170-20255	10-17
2X4-25355-00	24-14	256-83936-00	3-23	90175-06012	4-15
148-25359-00	24-13		25-26	90175-06013	26-17
431-25367-00	24-27	437-83936-00	27- 6	90179-08148	25-15
3R5-25371-00	24-42		28-16	90179-08299	1- 5
3R4-25381-00	24-37	437-83936-10	25-27	90179-12244	9-18
2K8-25388-00	24-34	3R4-83976-00	28-15	90179-20255	11-29
2J5-25394-00	23-29	3R5-85500-20	3- 1	90179-25033	19-19
2X5-25394-00	24-23	3R5-85509-20	3- 3	90185-08054	14-14
583-25412-00	24-25	3R5-85511-20	3- 4	90201-06067	15- 2
431-25444-00	24-24	3R5-85512-20	3- 5		15- 9
431-25446-00	24-24	3R5-85515-20	3- 8		15-13
431-25448-03	24-24	1W2-85516-20	3- 7	90201-06407	21- 8
431-25450-04	24-24	3R5-85540-20	3-20	90201-06571	16- 5
3R4-26111-00	25- 1	3R5-85547-00	3-22		16-20
583-26241-00	25- 2	3R5-85550-20	3- 2	90201-08083	25-17
583-26242-00	25- 3	2K7-85555-00	14-25		28- 3
431-26243-00	25- 4	2W6-85580-20	3- 6		28-10
1W1-26249-00	25- 5	341-92090-60	20-18	90201-08092	10-22
431-26281-01-98	25- 6	90101-06278	23-14	90201-08544	20-32
431-26282-01-98	25- 7		24-15	90201-12593	3-18
3R8-26287-00	25- 9	90101-06304	22- 5	90201-13202	14-18
2K8-26311-01	25-10	90101-08428	26-22	90201-14536	26- 9
3R4-26335-00	25-11	90101-08475	24-35	90201-15234	9-15
3R8-26341-00	25-13	90102-08034	24-45	90201-17327	10-27
156-26347-00	25-18	90102-10006	26- 3	90201-17545	9- 8
382-26372-01	25-12	90105-12096	26-25	90201-20278	11-10
	25-14	90105-14136	19-13		11-21
3R4-27200-00	26- 6	90109-06410	28- 4	90201-20358	9- 4
2X4-27231-01	26-11		28-11	90201-25287	11- 4
3R4-27311-00-33	26- 1	90109-06551	6-17		11-14
3R4-27411-00-33	26-18	90109-08397	20-29	90202-06010	21-18
2X4-27412-00	26-19	90109-08512	6-15	90209-06187	15- 5
3R4-27421-00-33	26-20	90109-10550	18-24	90209-10195	19- 6
2X4-27422-00	26-21	90116-08218	24- 7	90209-12143	19- 5
2K7-28100-10	14-24	90116-08321	1- 4	90209-22082	11- 7
		90116-12315	1- 8		

NUMERICAL INDEX

PART NO.	REF. NO.	PART NO.	REF. NO.	PART NO.	REF. NO.
90209-22082	11-17	90480-12053	16- 6	92501-08010	7-16
90209-25085	2-12	90480-14102	4-16	92502-06016	18-35
	30-29	90480-15058	4-20	92506-06008	8-13
90215-20125	10-16	90480-22263	18-32	92506-06025	8- 5
90215-21121	11-28	90501-10245	26-15	92506-06035	8- 3
90240-06006	23-20	90501-12081	9-14	92701-06012	7- 7
90240-06040	26-12	90501-24408	10-12	92901-03100	4- 5
90240-08012	25-16	90506-16036	23- 9	92901-04100	3-11
90240-12074	18-28	90506-20192	26-10		3-13
90249-12008	26-16	90506-20223	6-10	92901-05100	17-30
90280-03017	2-15	90507-20002	24-11	92901-05200	17-31
90282-04036	12- 5	90507-20030	6- 3	92901-06100	4-19
90282-07019	10- 2	90507-29008	26- 2		6-19
90338-07011	7-10	90508-14423	10-28		16- 4
90339-13005	14-15	90508-20023	26-24		16-16
90340-12059	7-21	90508-20425	23-23		16-19
90380-12051	18-13	90508-26421	12- 8		17-21
90380-16077	17- 9	90508-30422	9- 5		21- 5
90381-17027	24-33	90508-32374	13- 7		25-22
90386-22097	17- 6	90560-12171	13- 6		27- 3
90387-07391	4-17	90560-15116	23- 2		28- 7
90387-07393	21- 7	91316-06020	4- 9		28-14
90387-07562	4-21	91316-06025	8-10	92901-06200	16-17
90387-080A8	24-44	91316-06045	7- 5		23-21
90387-08258	6-13	91316-06050	7- 4		26-13
90387-08699	24-48	91316-06060	7- 3	92901-06600	3-16
90387-15535	23-31	91316-06075	7- 2		6-20
90387-16776	7- 8	91401-20012	23-22		17-22
	7-12		25-19		21- 6
90387-17700	24-29		26-14		25-24
90387-17779	24-28	91401-20015	24-47	92901-08100	6- 7
90387-17780	24-32	91401-20025	18-27		10-21
90387-25663	11-26		26- 5		14- 6
90430-06016	8-14	91401-30022	18-30		17-18
	30-40	91402-16015	5-38		17-26
90430-12038	7-22	91402-20018	19- 9		20-31
	30-41	91810-05016	7-11	92901-08200	6- 5
90445-08376	7-20	91810-17016	1-11		14-13
90445-09300	21-24				14-19
90445-11182	21-20	92501-06012	7-14	92901-08600	6- 8
90446-09158	19-22		7-18		14- 7
90460-51109	4- 8		16-15		14-22
90460-68120	4-10	92501-06015	16- 3		17-19
90462-05005	27- 4		16-18		17-27
90462-14055	25-20	92501-06020	3-15	92901-10100	19- 7
90467-10008	21-21		17-20	92901-10200	14-10
90467-20030	4-13	92501-06025	25-21	92901-12100	3-19
90468-26048	9- 3		27- 2	92901-12600	18-29

NUMERICAL INDEX

REF.		REF.		REF.		REF.		REF.	
PART NO.	NO.	PART NO.	NO.	PART NO.	NO.	PART NO.	NO.	PART NO.	NO.
92901-16100	17-13	93306-30615	2-16	95302-10700	18-25	98701-05016	12- 6		
	24-38	93310-418E9	2- 5		19- 8	98902-06018	21-10		
92901-18100	10- 3		30-31	95302-10900	26- 4				
92902-03600	5-16	93310-42541	2-11	95311-08600	20-30				
92902-04200	16-14		30-30	95311-08700	10-23				
92902-05100	5-13	93311-62035	11-11	95601-06100	22- 8				
92902-06100	15- 4		11-23		28- 5				
	15- 8	93315-21721	10-25		28-12				
	15-12	93317-22214	17- 3	95601-08100	26-23				
	18-36	93332-00001	19-16	95601-10100	14-11				
92902-06200	22- 9	93332-00008	19-17	95611-08100	24-46				
92902-06600	18-37	93342-22208	17- 2	95701-08100	19-12				
92902-08200	16- 2	93399-99904	24-43	95701-12100	1-10				
92902-10600	18-26	93410-17008	9- 9	95702-06300	17-24				
92906-06100	8- 6	93410-20038	11-22	95702-08300	14-21				
92906-06600	8- 7	93430-10015	26- 7	95801-08075	14- 3				
93101-12004	13- 4	93430-10016	9-16	95811-08075	14- 8				
	30-48	93440-25019	11- 5	95811-08165	14-12				
93102-17004	10-26		11-15	95811-10055	14- 9				
	30-46	93440-50078	18-23	95821-08035	19-15				
93102-20009	23- 6	93450-19052	2- 4	95821-08040	19-10				
93102-25030	24- 5		30- 5	95821-08055	19-11				
93102-32136	11-25		30-10	97301-06012	21- 4				
	30-47		30-15	97301-06015	15- 7				
93103-30092	2-14		30-20		15-11				
	30-44		30-25	97301-06016	6-18				
93103-40091	2-17	93507-32009	9-13	97301-06020	26-26				
	30-45	93515-32029	10-19	97301-06022	28- 6				
93104-11056	24- 9	93604-26132	18-15		28-13				
93108-35004	17- 7	93606-14154	12-13	97301-06025	4-18				
93109-14021	26- 8	93608-25150	13- 5	97301-06050	17-23				
93109-20014	9-10	94130-21554	23-26	97301-08016	17-17				
	30-49	94151-18553	24-20	97301-08020	6- 6				
93109-22018	17- 8	94227-21123	23-27	97301-08025	14- 5				
93210-14104	8-12	94251-18150	24-21	97301-08035	17-25				
	30-39	94330-21084	23-28	97301-08055	14-20				
93210-29282	10- 5	94340-18086	24-22	97302-06020	15- 3				
	30-42	94416-21234	23-24	97302-06035	22- 7				
93210-31114	24-31	94425-18218	24-18	97321-06025	13- 3				
93306-00421	12- 4	94585-20108	24-40	97602-03108	5-15				
93306-20107	12-16	94685-20001	24-41	97702-40512	16-13				
93306-20203	23- 4	94700-00088	1- 3	98501-03008	4- 4				
93306-20205	23- 5	95301-06600	23-15	98501-04005	18- 4				
93306-20310	24- 3		24-17	98501-04014	3-12				
93306-20316	24- 4		25-23	98501-04035	3-10				
93306-20540	11- 2	95301-06700	23-17	98501-05010	17-29				
93306-20544	11-24		26-27	98501-05015	5-12				
93306-30615	2-13	95301-08700	24-36	98501-05016	25- 8				

PARTS NAME INDEX

DESCRIPTION	REF. NO.
AIR CLEANER CASE ASSY	4-11
AIR VALVE COMP.	20-22
ARM, tensioner	17-14
AXLE, drive	11-12
AXLE, main (14T)	11- 1
AXLE, wheel	23-30
*	24-37
BALL	9-13
*	10-19
BAND	19-21
*	20-19
BAND, battery	3-21
BAND, boot	20-18
BAND, rim (3.00-21)	23-28
BAND, rim (4.00-18)	24-22
BAND, switch cord	3-23
*	25-26
*	25-27
*	27- 6
*	28-16
BAND, tank fitting 1	21-11
BAR, shift fork Guide 1	12-14
BAR, shift fork Guide 2	12-15
BAR, tension	24-42
BASE, magneto	3- 3
BEARING	11- 2
*	11-24
*	12- 4
*	17- 2
*	19-16
*	19-17
*	24-43
BEARING (B6201)	12-16
BEARING (B6202)	23- 5
BEARING (B6202RS)	23- 4
BEARING (B6203)	24- 4
BEARING (B6203RS)	24- 3
BEARING (B6306)	2-13
*	2-16
BEARING, cylindrical	2- 5
*	2-11
*	10-25
*	11-11
*	11-23
*	17- 3
*	30-30
*	30-31
BODY, cap	21-22

PARTS NAME INDEX

DESCRIPTION	REF. NO.
BODY, float chamber 1	5- 2
BOLT	4- 9
*	4-18
*	6- 6
*	6-15
*	6-17
*	6-18
*	7- 2
*	7- 3
*	7- 4
*	7- 5
*	8-10
*	13- 3
*	14- 5
*	14-20
*	15- 3
*	15- 7
*	15-11
*	17-17
*	17-23
*	17-25
*	18-24
*	20-29
*	21- 4
*	22- 5
*	22- 7
*	23-14
*	24-15
*	24-35
*	25-25
*	26-22
*	26-26
*	28- 4
*	28- 6
*	28-11
*	28-13
BOLT, axle holder	20-28
BOLT, cap	20-20
BOLT, flange	14- 3
*	14- 8
*	14- 9
*	14-12
*	19-10
*	19-11
*	19-15
BOLT, hexagon socket head	20-27
BOLT, stopper	12- 9
BOLT, stud	1- 4

PARTS NAME INDEX

DESCRIPTION	REF. NO.
BOLT, stud	1- 8
*	1- 9
*	24- 7
BOLT, washer based	19-13
*	26-25
BOLT, with hole	24-45
*	26- 3
BOLT, with washer	21- 9
BOOT	20-17
BOSS, clutch	10- 8
BOSS, kick crank	9-12
BRACKET, footrest 1	26-19
BRACKET, footrest 2	26-21
BRACKET, front upper 1	14- 2
BRACKET, rear upper 1	14- 4
BRACKET, seat	22- 3
*	22- 4
BRAKE SHOE COMP.	23- 8
*	24-10
BUSH	17- 6
BUSH, rear shock absorber	18- 3
BUSH, shock absorber lower	18-12
BUSH, solid	17- 9
*	18-13
*	24-33
C.D.I. MAGNETO ASSY	3- 1
C.D.I. UNIT ASSY	3-20
CABLE, brake	25-13
CABLE, clutch	25-11
CABLE, throttle 1	25-10
CAMSHAFT	23-10
*	24-12
CAP, case	18- 8
CAP, grip lower	25- 7
CAP, grip upper	25- 6
CAP, plunger	5-36
CARBURETOR ASSY 1	5- 1
CHAIN, drive (DID520DS 108L)	24-40
CIRCLIP	2- 4
*	9- 9
*	9-16
*	11- 5
*	11-15
*	11-22
*	18-23
*	26- 7
*	30- 5
*	30-10

PARTS NAME INDEX

DESCRIPTION	REF. NO.
CIRCLIP	30-15
*	30-20
*	30-25
CLAMP	3- 9
*	25-20
*	27- 4
CLAMP, hose	4- 8
*	4-10
CLIP	4-13
*	5-21
*	5-34
*	9- 3
*	21-21
CLIP, Plunger	5-37
CLUTCH ASSY	10- 6
COIL, Pulsar	3- 6
COIL, source	3- 4
*	3- 5
COLLAR	4-17
*	4-21
*	6-13
*	7- 8
*	7-12
*	11-26
*	21- 7
*	23-31
*	24-28
*	24-29
*	24-32
*	24-44
*	24-48
CONNECTING ROD ASSY	30-26
CONNECTOR	5-28
CONNECTOR, suction Pipe	7-19
COVER	14-23
*	18-16
COVER, ball race 2	19-18
COVER, caP Grip	25- 9
COVER, crankcase 1	8- 1
COVER, crankcase 2	8- 4
COVER, crankcase 3	8- 8
COVER, dust seal	20- 7
COVER, handle lever	25-12
*	25-14
COVER, hub dust	23-32
*	24-27
COVER, kick lever	9-17
COVER, Plate	24-30
COVER, Plunger caP	5-40

PARTS NAME INDEX

DESCRIPTION	REF. NO.
COVER, semi-double seat	22- 2
COVER, side (L.H)	16- 1
COVER, side (R.H)	16- 8
COVER, thrust 1	18-31
COVER, thrust 2	17- 5
CRANK 1	2- 7
CRANK 2	2- 8
CRANKCASE 1	7- 1
CRANKCASE 2	7- 9
CRANKSHAFT ASSY	2- 6
CROWN, handle	19- 1
CYLINDER COMP., front fork	20-11
CYLINDER 1	1- 6
DAMPER	3-22
*	16- 9
*	16-10
DAMPER, locating 1	16- 7
*	21-25
DAMPER, locating 2	21- 2
DAMPER, locating 3	21-26
DAMPER, muffler	6-12
DAMPER, seat	22- 6
DAMPER, sub tank	18-33
DUMPER SUB ASSY	18- 2
ELEMENT ASSY, air cleaner	4-14
EMBLEM	16-21
END, rod 1	23-18
END, rod 2	23-19
EXHAUST PIPE ASSY 1	6- 1
FENDER, front	15- 1
FENDER, rear	15- 6
FLANGE, sPacer	24- 6
FLANGE, sPacer 2	23- 3
FLAP	15-14
FLOAT	5- 7
FOOTREST 1	26-18
FOOTREST 2	26-20
FDRK, shift 1	12-10
FORK, shift 2	12-11
FDRK, shift 3	12-12
FRAME COMP	14- 1
FRONT FORK ASSY	20- 1
FUEL COCK ASSY 1	21-12
FUEL TANK COMP.	21- 1
GASKET	7-22
*	8-14

PARTS NAME INDEX

DESCRIPTION	REF. NO.
GASKET	20-10
*	20-25
*	21-13
*	30-40
*	30-41
GASKET KIT	30-32
GASKET, caP	21-23
GASKET, crankcase cover	8- 2
*	30-37
GASKET, crankcase cover 3	8- 9
*	30-38
GASKET, cylinder	1- 7
*	30-34
GASKET, cylinder head 1	1- 2
*	30-33
GASKET, drain Plug	20-26
GASKET, exhaust Pipe	6- 2
GASKET, float chamber	5- 3
*	30-36
GASKET, valve seat	4- 6
*	30-35
GAUGE, air	14-27
GEAR, kick (26T)	9- 2
GEAR, Primary drive (24T)	10- 1
GEAR, sPcket idle (21T)	9- 7
GEAR, 1st wheel (30T)	11-20
GEAR, 2nd Pinion (16T)	11- 9
GEAR, 2nd wheel (28T)	11-13
GEAR, 3rd Pinion (19T)	11- 6
GEAR, 3rd wheel (25T)	11-18
GEAR, 4th Pinion (22T)	11- 3
GEAR, 4th wheel (23T)	11-19
GEAR, 5th Pinion (24T)	11- 8
GEAR, 5th wheel (20T)	11-16
GRAPHIC SET	21-27
GRIP (L.H)	25- 2
GRIP (R.H)	25- 3
GROMMET	4-16
*	4-20
*	16- 6
*	18-32
GUARD, chain	17-15
GUARD, mud	15-10
GUIDE, cable	5-20
*	20-23
GUIDE, sPring	9- 6
GUIDE, sPring 1	18-20

PARTS NAME INDEX

DESCRIPTION	REF. NO.
GUIDE, sPring 2	18-21
HANDLEBAR	25- 1
HEAD, cylinder 1	1- 1
HOLDER	5-39
*	7-15
HOLDER, cable	19- 2
HOLDER, damPer	19- 4
*	21- 3
HOLDER, handle lower	19- 3
HOLDER, handle uPPer	19-14
HOLDER, lever 1	28- 1
HOLDER, lever 2	28- 8
HOLDER, sub tank	18-34
HOOK, sPring	6- 9
HOSE	7-20
*	19-22
*	21-20
*	21-24
HOUSING, seal ring	18- 7
HUB, front	23- 1
HUB, rear	24- 1
IGNITION COIL ASSY	27- 1
JET, main (#380)	5- 6
JET, main (#390)	5- 6
JET, main (#400)	5- 6
JET, Pilot (#50.0)	5- 4
JOINT, cable	25-18
JOINT, carburetor	4- 7
JOINT, chain	24-41
KEY, straight	10- 2
*	12- 5
KEY, woodruff	2-15
KICK AXLE ASSY	9- 1
KICK CRANK ASSY	9-11
LEAD WIRE ASSY	3- 8
LEVER 1	28- 2
LEVER 2	28- 9
LEVER, camshaft	24-14
LEVER, camshaft 1	23-11
LEVER, camshaft 2	23-12
LEVER, cock	21-16
NEEDLE	5-33
NEEDLE VALVE ASSY	5- 8
NOZZLE, main	5- 5
NUT	1- 5
*	3-17
*	9-18

PARTS NAME INDEX

DESCRIPTION	REF. NO.
NUT	10- 4
*	10-17
*	10-23
*	11-29
*	17-12
*	18-18
*	18-25
*	19- 8
*	19-19
*	20-30
*	23-15
*	23-17
*	24-17
*	24-26
*	24-36
*	24-39
*	25-15
*	25-23
*	26-27
NUT, adjusting	18-14
NUT, cable adjusting	5-19
*	5-26
NUT, flange	1-10
*	14-21
*	17-24
*	19-12
NUT, self-locking	14-14
NUT, slotted	26- 4
NUT, u	14-11
*	22- 8
*	24-46
*	26-23
*	28- 5
*	28-12
NUT, wing	4-15
*	26-17
O-RING	5-18
*	5-32
*	8-12
*	10- 5
*	20-24
*	21-15
*	24-31
*	30-39
*	30-42
OIL SEAL	2-14
*	2-17
*	9-10

PARTS NAME INDEX

DESCRIPTION	REF. NO.
OIL SEAL	10-26
*	11-25
*	13- 4
*	17- 7
*	17- 8
*	20- 5
*	23- 6
*	24- 5
*	24- 9
*	26- 8
*	30-44
*	30-45
*	30-46
*	30-47
*	30-48
*	30-49
OIL SEAL KIT	30-43
PANEL 1	16-12
PEDAL, brake	26- 6
PEDAL, shift	13- 2
PIN	26-16
PIN, clevis	18-28
*	23-20
*	25-16
*	26-12
PIN, cotter	5-38
*	18-27
*	18-30
*	19- 9
*	23-22
*	24-47
*	25-19
*	26- 5
*	26-14
PIN, crank 1	2- 9
*	30-28
PIN, dowel	1-11
*	7-11
*	12-13
*	13- 5
*	18-15
PIN, float	5- 9
PIN, Piston	2- 3
*	30- 4
*	30- 9
*	30-14
*	30-19
*	30-24

PARTS NAME INDEX

DESCRIPTION	REF. NO.
PIPE	5-11
*	5-14
PISTON (STD)	2- 1
*	2- 1
*	30- 2
*	30- 2
PISTON (1ST O/S 0.25MM)	2- 1
*	30- 7
PISTON (2ND O/S 0.50MM)	2- 1
*	30-12
PISTON (3RD O/S 0.75MM)	2- 1
*	30-17
PISTON (4TH O/S 1.00MM)	2- 1
*	30-22
PISTON ASSY (STD)	30- 1
PISTON ASSY (1ST O/S)	30- 6
PISTON ASSY (2ND O/S)	30-11
PISTON ASSY (3RD O/S)	30-16
PISTON ASSY (4TH O/S)	30-21
PISTON RING SET (STD)	2- 2
*	30- 3
PISTON RING SET (1ST O/S)	2- 2
*	30- 8
PISTON RING SET (2ND O/S)	2- 2
*	30-13
PISTON RING SET (3RD O/S)	2- 2
*	30-18
PISTON RING SET (4TH O/S)	2- 2
*	30-23
PLATE	5-29
*	7-17
PLATE, bearing cover	7- 6
*	7-13
PLATE, brake shoe	23- 7
*	24- 8
PLATE, clutch 2	10-10
PLATE, friction	10-11
PLATE, number	19-20
PLATE, Pressure 1	10- 9
PLATE, side 1	12- 3
PLATE, thrust 1	10-15
PLUG	7-10
*	14-15
PLUG CAP ASSY	27- 5
*	27- 5
PLUG, drain	20-33
PLUG, oil level	8-11
PLUG, screw	5-31

PARTS NAME INDEX

DESCRIPTION	REF. NO.
PLUG, sPark	1- 3
PLUG, straight screw	7-21
PLUNGER, starter	5-42
PRIMARY DRIVEN GEAR COMP.(63T)	10- 7
PROTECTOR, chain	17-28
PULLER, chain 1	24-34
PULLER, rotor	14-25
PUSH LEVER ASSY	10-29
REAR ARM COMP.	17- 1
REED VALVE ASSY	4- 1
REED, valve	4- 2
RIM (1.60-21)	23-24
RIM (2.50-18)	24-18
RING, leaf	25- 5
RING, snap	20- 4
ROD, brake	26-11
ROD, connectinG	2-10
*	23-16
*	30-27
ROD, Push	18- 5
ROD, Push 1	10-18
ROD, Push 2	10-24
ROTOR ASSY	3- 2
SCREW	10-20
*	21-19
SCREW, air adjustinG	5-23
SCREW, bind	21-10
SCREW, boot band	20-34
SCREW, flat head	7- 7
*	12- 6
SCREW, lever fittinG	21-17
SCREW, Pan head	3-10
*	3-12
*	3-14
*	3-15
*	4- 4
*	5-12
*	7-14
*	7-16
*	7-18
*	8- 3
*	8- 5
*	8-13
*	16- 3
*	16-15
*	16-18
*	17-20
*	17-29

PARTS NAME INDEX

DESCRIPTION	REF. NO.
SCREW, Pan head	18- 4
*	18-35
*	25- 8
*	25-21
*	27- 2
SCREW, Pan head with washer	5-15
SCREW, tappinG	16-13
SCREW, throttle	5-25
SCREW, with washer	10-13
SEAL	4-12
SEAL 1	16-11
SEAL, camshaft	23-13
*	24-13
SEAL, dust	18- 6
*	20- 6
SEAL, Guard	17-10
SEAL, mud Guard	15-15
SEAT, sPrinG	5-35
SEAT, sPrinG lower	18-22
SEAT, sPrinG upper	18-17
*	20-15
SEGMENT	12- 2
SEMI-DOUBLE SEAT ASSY	22- 1
SHAFT	14-16
SHAFT, Pivot	17-11
SHIFT CAM ASSY	12- 1
SHIFT SHAFT ASSY	13- 1
SHIM (0.3T)	17- 4
SHIM, camshaft	24-16
SHOCK ABSORBER ASSY, rear	18- 1
SILENCER, exhaust	6-11
SPACER	3- 7
*	13- 6
*	20-16
*	23- 2
SPACER 1	10-14
SPACER, bead	23-29
*	24-23
SPACER, bearing	24- 2
SPANNER, sPecial	14-26
SPINDLE, taPer	20- 9
SPOKE SET, front	23-25
SPOKE SET, rear	24-19
SPRING	18-19
*	21-14
*	29- 1
*	29- 1
SPRING, air adjustinG	5-22

PARTS NAME INDEX

DESCRIPTION	REF. NO.
SPRING, compression	9-14
*	10-12
*	26-15
SPRING, front fork	20-14
*	29- 2
*	29- 2
SPRING, Plunger	5-41
SPRING, rebound	20-12
SPRING, tension	6- 3
*	6-10
*	23- 9
*	24-11
*	26- 2
*	26-10
SPRING, throttle valve	5-17
SPRING, torsion	9- 5
*	10-28
*	12- 8
*	13- 8
*	23-23
*	26-24
SPROCKET, drive (13T)	11-27
SPROCKET, drive (14T)	11-27
SPROCKET, drive (15T)	11-27
SPROCKET, driven (44T)	24-24
SPROCKET, driven (46T)	24-24
SPROCKET, driven (48T)	24-24
SPROCKET, driven (50T)	24-24
STAND, side	26- 1
STAY, muffler 1	6-16
STAY, muffler 2	6- 4
STOPPER LEVER ASSY	12- 7
STOPPER, bump	18- 9
STOPPER, reed valve	4- 3
SUPPORT, bump stop	18-10
SUPPORT, chain	17-16
SWITCH, handle 1	28-15
TENSIONER	14-17
TIRE (3.00-21)	23-26
TIRE (5.10-18)	24-20
TOOL KIT	14-24
TDP, mixing chamber	5-24
TUBE (2.75-21)	23-27
TUBE (5.10-18)	24-21
TUBE, inner 1	20- 8
TUBE, outer 1	20- 2
TUBE, outer 2	20- 3
TUBE, throttle guide	25- 4

PARTS NAME INDEX

DESCRIPTION	REF. NO.
UNDER BRACKET COMP.	20-13
UPPER BRACKET SUB ASSY	18-11
VALVE, throttle 1	5-27
WASHER	2-12
*	5-16
*	11- 7
*	11-17
*	15- 5
*	16- 2
*	18-37
*	19- 5
*	19- 6
*	22- 9
*	24-25
*	30-29
WASHER, lock	10-17
*	11-28
WASHER, main Jet	5-30
WASHER, needle valve	5-10
WASHER, outer tube	20-21
WASHER, Plain	6- 5
*	14-10
*	14-13
*	14-19
*	16-14
*	16-17
*	17-31
*	23-21
*	26-13
WASHER, Plate	3-16
*	3-18
*	6- 8
*	6-20
*	8- 7
*	9- 4
*	9- 8
*	9-15
*	10-22
*	10-27
*	11- 4
*	11-10
*	11-14
*	11-21
*	14- 7
*	14-18
*	14-22
*	15- 2
*	15- 9

PARTS NAME INDEX

DESCRIPTION	REF. NO.
WASHER, Plate	15-13
*	16- 5
*	16-20
*	17-19
*	17-22
*	17-27
*	18-26
*	18-29
*	20-32
*	21- 6
*	21- 8
*	21-18
*	25-17
*	25-24
*	26- 9
*	28- 3
*	28-10
WASHER, special	6-14
WASHER, spring	3-11
*	3-13
*	3-19
*	4- 5
*	4-19
*	5-13
*	6- 7
*	6-19
*	8- 6
*	10- 3
*	10-21
*	14- 6
*	15- 4
*	15- 8
*	15-12
*	16- 4
*	16-16
*	16-19
*	17-13
*	17-18
*	17-21
*	17-26
*	17-30
*	18-36
*	19- 7
*	20-31
*	21- 5
*	24-38
*	25-22
*	27- 3

PARTS NAME INDEX

DESCRIPTION	REF. NO.
WASHER, sPring	28- 7
*	28-14

